

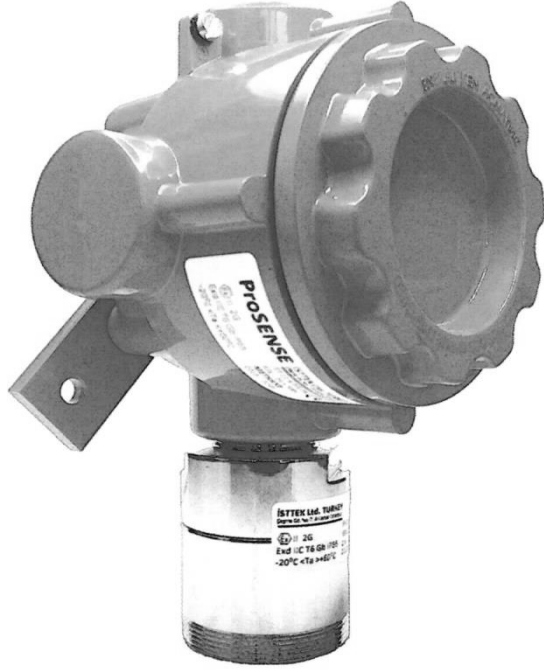

PROSENSE P Series Gas Detector Installation and User Manual



Prosense Teknoloji San. Ltd. Şti.
Cumhuriyet Mah. Mermer sok. No:16 34876 Kartal/İstanbul
Tel: (90) 216 306 77 88 Faks: (90)216 473 81 29
www.prosense.com.tr

WARNING!

This manual must be carefully read by all persons who have or will have the responsibility for installing, using or servicing this product.

Like any equipment, this product will perform as designed only if installed, used and serviced in accordance with the manufacturer's instructions. Otherwise, it could fail to perform as designed and persons who rely on this product for their safety could suffer severe personal injury or death.

The warranties made by Prosense with respect to this product are voided if the product is not installed, used and serviced in accordance with the instructions in this user guide. Please protect yourself and other by following them.

Important Remark

The detector has been factory-tested before delivery. The commissioning has to be terminated by a function test of the complete gas detection system.



**DO NOT REMOVE COVER WHEN ENERGISED!
ELECTROSTATIC HAZARD - CLEAN ONLY WITH A DAMP CLOTH!**

CONTENTS

Safety Information.....	4
Strictly follow the Instructions for Use.....	4
Maintenance	4
Use in areas subject to explosion hazards	4
Liability for proper function or damage	4
Intended Use	5
Introduction.....	7
Detector Body.....	8
Sensor Head:	8
Installation:.....	9
Mounting The Detector:.....	10
Electrical Connections	11
Cabling.....	13
Detector Grounding	13
Default Configuration	14
Detector Configuration.....	15
4-20 mA Output:.....	15
Detector RS485 Serial Communication:	15
Detector Relay Module:	17
System Status	20
First Time Switch On (Commissioning).....	20
Calibration	21
Maintenance	22
Proactive maintenance:.....	22
Operational Life:.....	22
Servicing	22
Sensor replacement:	22
Pellistor sensor replacement:.....	23
Electrochemical sensor:	23
Infrared Sensor:.....	23
Sensor PCB replacement:	24
Sinter replacement:.....	24
Sensor head replacement:	24
Detector Transmitter board replacement:.....	24
Detector Relay Module replacement:.....	25
Spare Parts	26
General Specification	28
Safety instruction for hazardous area installation	29
Certificate	31
Declaration	35
Warranty Statement.....	36

Safety Information

Ensure that this Operating Manual is read and understood **BEFORE** installing / operating / maintaining the equipment. Pay particular attention to Warnings and Cautions. All document Warnings are listed here and repeated where appropriate at the start of the relevant chapter(s) of this Operating Manual. Cautions appear in the sections/sub-sections of the document where they apply.

Strictly follow the Instructions for Use

Any use of the detectors requires full understanding and strict observation of these instructions. The detector is only to be used for purposes specified here.

The cover on Detector must be kept tightly closed until power to the detector is isolated otherwise ignition of a flammable atmosphere can occur. Before removing the cover for maintenance or calibration purposes, ensure the surrounding atmosphere is free of flammable gases or vapours.

Detectors must be protected from extreme vibration and direct sunlight in hot environments as this may cause the temperature of the detector to rise above its specified limits and cause premature failure.

Maintenance

It is recommended to obtain a service contract Prosense to carry out all repairs. Only authentic Prosense spare parts must be used, substitute components may invalidate the certification and warranty of the detector. Maintenance and calibration operations must only be performed by qualified service personnel.

Use in areas subject to explosion hazards

Equipment or components which are used in potentially explosive atmospheres and have been tested and approved according to international or European regulations may be used only under the conditions specified here. Modifications of components or the use of faulty or incomplete parts are not permitted. In case of repairs of equipment or components, the national regulations must be observed.

Liability for proper function or damage

The liability for the proper function of the detector is irrevocably transferred to the owner or operator to the extent that the detector is serviced or repaired by personnel not employed or authorized by Prosense or if the sensing head is used in a manner not conforming to its intended use. Prosense cannot be held responsible for damage caused by non-compliance with the recommendations given above. The warranty and liability provisions of the terms of sale and delivery of Prosense are likewise not modified by the recommendations given above.

Intended Use

The P series detectors are intended to be used for stationary, continuous monitoring for combustible gas/air or vapour/air mixtures below the Lower Explosion Limit (LEL) and toxic gas/air mixtures in particule per million (PPM) units. The detectors are marked by the device categories II 2G that can be operated in hazardous areas with potentially explosive atmospheres of zones 1 and 2. The type of protection for gas explosion protection according to device category 2 (zones 1 or 2) is flameproof enclosure and increased safety, "db". The enclosure protection is IP 65.

According to the ATEX Directive 2014/34/EU the detector is an assembly consisting of three components (Sensor Head, enclosure and cable gland), where all these three components are type approved according to ATEX Directive 2014/34/EU and marked by the device category II 2G. Thus this detector is suitable to be operated in hazardous areas with potentially explosive atmospheres of zone 1 and zone 2. The P series detector comprises a gas sensor type Ex-proof (protection type flameproof enclosure db type). P Series detector for flammable gases performs % 0 to % 100 LEL measurement range; for toxic gases the measurement range would be vary. The measurement range and environmental conditions are written on each detector label.

Hazardous area classifications:

Zone 0: An area classified as Zone 0 will have ignitable concentrations of flammable gases, vapours or liquids either continuously present or present for long periods of time under normal operating conditions

Zone 1: An area classified as Zone 1 is likely to have ignitable concentrations of flammable gases, vapours or liquids present under normal operating conditions. Flameproof (Ex db) detectors are suitable for use in Zone 1.

Zone 2: An area classified as Zone 2 is not likely to have ignitable concentrations of flammable gases, vapours or liquids present under normal operating conditions. Flameproof (Ex db) detectors are suitable for use in Zone 2.

Not to be used in oxygen enriched atmospheres.

P detectors for flammable gases with pellistor sensor are designed to detect gases or vapours in air and not inert or oxygen deficient atmospheres. P oxygen detectors can measure in oxygen deficient atmospheres.

In conjunction with the central controllers Prosense detectors with preadjusted alarm thresholds audible and visible alarm devices or automatic countermeasures can be activated before the detected gases or vapours can form dangerous flammable or toxic mixtures with air. Please be alerted in following special conditions may have impact on measuring function due to the nature of measuring method:

1. Very high gas concentrations

The measuring method of P series detector based on heat produced by reaction on the oxidation of a flammable gas when pellistor sensor used. There is not enough oxygen in the sensor to perform oxidation process correctly in case of high gas concentrations. Hence the measuring signal decreases at high gas concentrations and even can lead to measuring signal within the measuring range again. In case of high flammable gas concentration, do not reset latching alarms without having ensured a safe condition in the environment via performing necessary checks.

2. Minimum oxygen concentration

The measuring principle of heat of reaction needs a minimum oxygen concentration of 15 % by volume; otherwise the measuring values will be too low because of oxygen deficiency.

3. Long-term gassing with methane at very low temperatures

If the Prosense P series flammable gas detectors with pelistör sensor are operated applying with methane at very low temperatures, the measuring signal at long term exposition may decrease after alarm activation and may lead to misinterpretation.

If a gas alarm occurs, necessary actions need to be taken immediately. The decrease of the measuring signal does not mean that the gas concentration has been decreased. We recommend to keep alarms on the associated controllers and not to reset these alarms without performing measurement with an independent gas detector to make sure conditions are safe.

Introduction

The Prosense comprises a gas detector body and a choice of sensors heads for detecting flammable gas, toxic gas and oxygen. The construction of Prosense allows it to be used in hazardous area locations; it may also be used in other areas not classified as hazardous.

Prosense detectors can be configured with a wide range of different sensors may be used to detect a broader range of target gases. The detector can be configured with optional relay board features three programmable relays for controlling external equipment e.g. alarms, sirens, valves or switches. The detector provides an industry standard 3-wire, 4-20mA source or sink output for connection to a dedicated gas detection control system or PLC.

Prosense detectors comprises of the main parts as shown below:

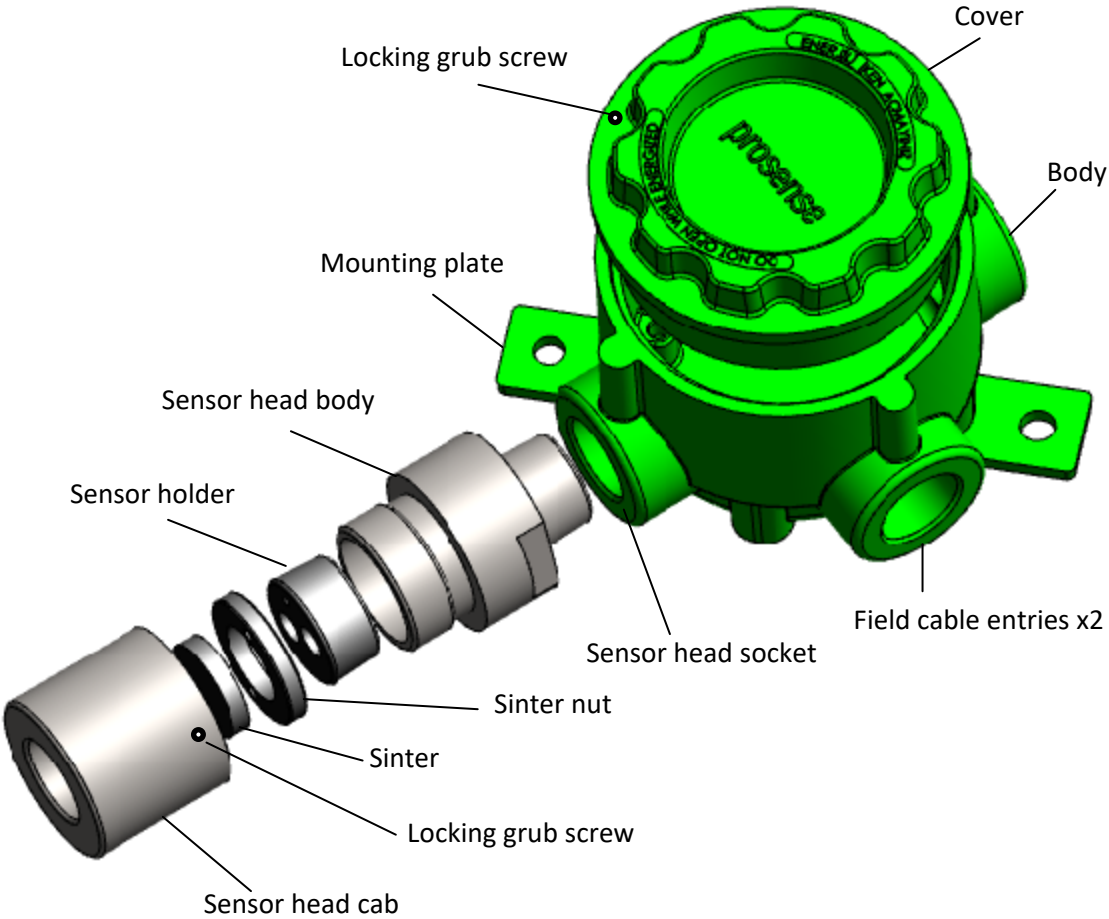

Diagram 1: Exploded view

Detector Body

The detector enclosure has three threaded entries. The two cable entries either side of the upper part of the transmitter housing are for connecting the power source, signal output and relay contacts to associated signalling equipment. The bottom entry allows direct connection of the sensor socket. There is a mounting plate incorporated into the transmitter housing allowing for various mounting configuration options.

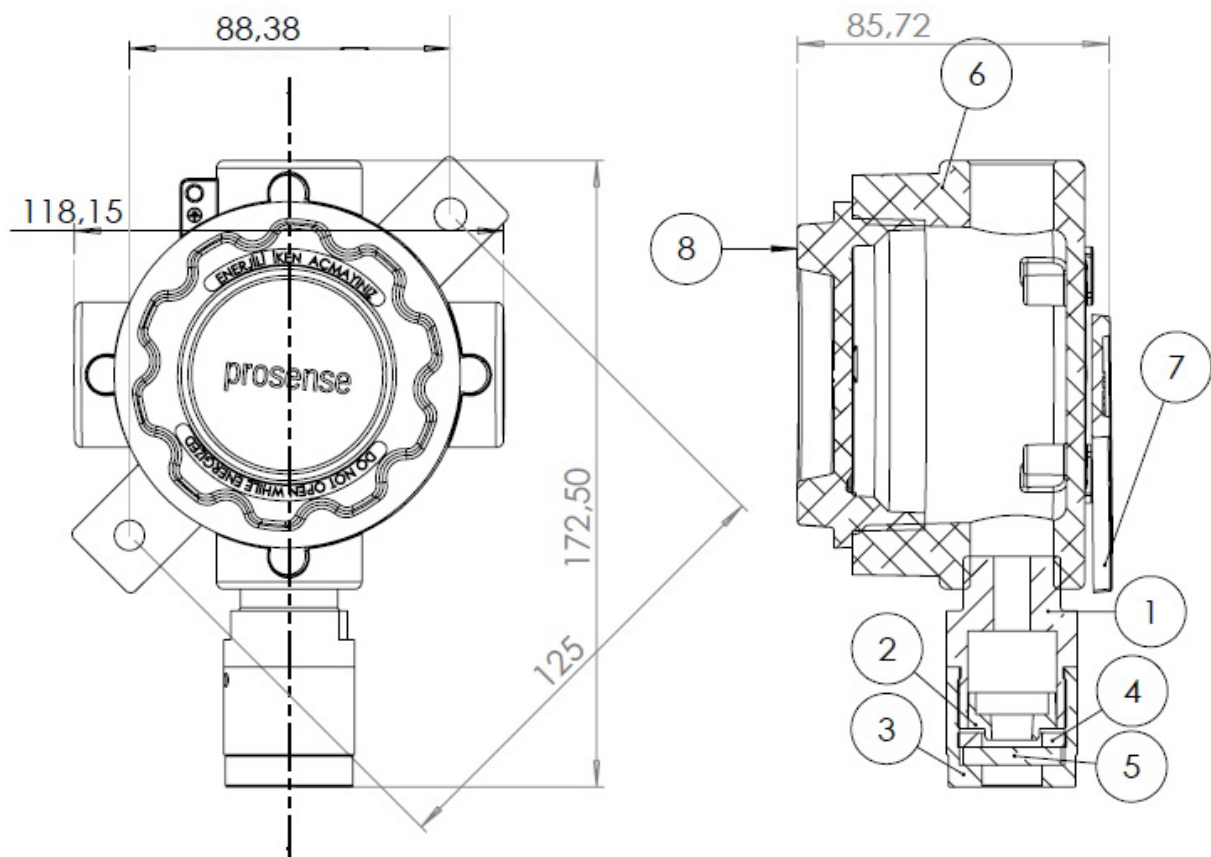

Diagram 2: Detector body and Sensor Head components

- 1 : Sensor head body
- 2 : Sensor holder
- 3 : Sensor head cap
- 4 : Sinter nut
- 5 : Sinter
- 6 : Junction box – Detector body
- 7 : Wall mounting adapter
- 8 : Junction box cover

Sensor Head:

The Prosense sensor head designed to detect flammable, toxic gases and oxygen. They may include infrared, pellistor or electrochemical sensors depending on the target gas and range.

Installation:

Gas detectors should be mounted where a potential hazard of gas is most likely to be present. The following points should be noted when locating gas sensors.

- When locating detectors consider the possible damage caused by natural events e.g. rain or flooding.
- Consider ease of access to the gas detector for functional testing and servicing.
- Consider how escaping gas may behave due to natural or forced air currents.

Note: The placement of gas detectors should be determined following the advice of experts having specialist knowledge of gas dispersion, experts having knowledge of the process plant system and equipment involved, safety and engineering personnel. The agreement reached on the location of detectors should be recorded.

Each gas has different nature depending on their density. The density of which is lower than air, such as hydrogen, methane or ammonia the sensor head must be located above a possible leak or at the highest points at which major concentrations of gas may be found. The gases and vapours with a density greater than air, the sensor head must be installed beneath a possible leak or at the lowest points at which such gases and vapours may be present.

Prosense may provide cable gland together with detector in regards to customer requests. The cable gland provided by Prosense has ATEX certification and provides at least IP65 level protection. The cable glands are only suitable for fixed installations. Cable gland body should be fixed to related entry with 20Nm torque. Cables shall be effectively clamped to prevent pulling or twisting. To provide necessary protection cable gland coupling should be fixed with 20Nm torque when used with three sealings; 18Nm when used with two sealings; 16Nm when used with one sealing. It is the final assemblers/users responsibility to ensure the threaded joint between cable gland and the enclosure meet all the requirements of the applicable standards for the assembly. Cable gland sealings are suitable for the circular type cables. If other shaped cables will be used the sealings should be replaced with suitable ones. The cable glands provided by Prosense are suitable to use temperature range in which detector works.

Prosense may provide plugs and adapters together with detector in regards to customer requests. The plugs and adapters provided by Prosense have ATEX certification and provides at least IP65 level protection. These parts should be mounted to detector body in such a way that accidental rotation or loosening will be prevented. Plug should be fixed to related entry with 20Nm torque. It is the final assemblers/users responsibility to ensure the threaded joint between fitting and the enclosure meet all the requirements of the applicable standards for the assembly. For adapters and plugs with nominal size of thread equal or lower than 25 mm aluminium alloy shall not be used. Only one adapters permitted for each cable entry; plugs shall not be used with adapters. The plugs and adapters provided by Prosense are suitable to use temperature range in which detector works.

The user-supplied cable gland, plug and adapter must be ATEX certified. Components that do not have an ATEX certificate cannot be used.

Mounting The Detector:

The detector should be mounted vertically as the sensor head pointing downwards. Detector has to be mounted such that the sensor's gas entrance area.

The install location

- should be isolated from vibration, direct sun light and have temperature stability
- avoided external influences such as splashing water, oil, corrosive aerosols
- should have at least 30 cm free space beneath the sensor head to provide accessibility for calibration work.
- should be in air flow between possible leak or collection point and possible source of ignition.

Prosense do not recommend to install detectors to :

- directly above a cooking unit,
- directly above a sink unit,
- close to an extractor unit,
- outdoor without protection against the rain,
- in places where temperature is outside the admissible operating range,
- in corrosive environments,
- inside air vents.
- in environments where silicon can be found.

The Prosense detector has an independent mounting plate consisting of two mounting holes and two holes to attach to detector body. The mounting plate can be adjustable on two diagonal way on to detector body. The detector may be fixed directly to a surface mounting. Follow below steps to mount the detector:

- 1- Decide which diagonal way to use and adjust mounting plate on detector body if necessary.
- 2- Check and make sure mounting plate is completely fixed to detector body
- 3- Mount the detector to the surface via using two outer mounting holes on mounting plate.

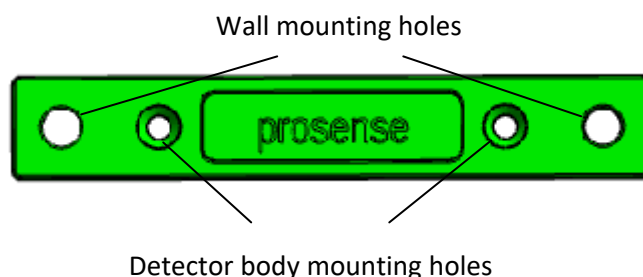

Diagram 3: Detector mounting plate

The mounting plate installed in below position at factory:

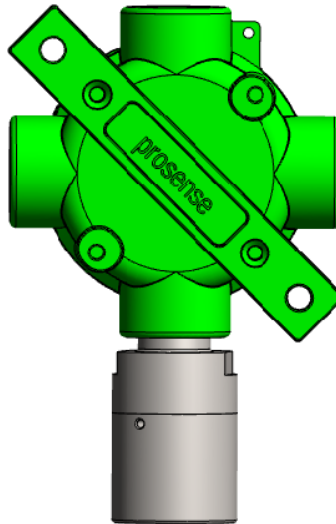

Diagram 4: Default installation of mounting plate

Electrical Connections

Caution: All electrical connections should be made in accordance with any relevant local or national legislation, standards or codes of practice.

Prosense detectors can operate between 12 - 24 VDC. The connection socket located on main board as given in Diagram 8 and details given in below table 2:

Output	Usage
V +	Power input (+) 12VDC – 24VDC
V -	Power input (-) 12VDC – 24VDC
S	Current Output Signal (4mA – 20mA)

Table 1 : Detector output ports and their usage

The detector designed to give 4 - 20 mA current output signal. It is also possible to get voltage output via using an additional resistor. Below table 3 gives recommended resistor specifications to get correct voltage output from detector depending of the power source level:

Detector Power VDC	Resistor	Signal level (4mA – 20mA)
12 VDC – 24 VDC	250 Ω, tolerance %1	1 VDC – 5 VDC
12 VDC – 24 VDC	500 Ω, tolerance %1	2 VDC – 10 VDC

Table 2 : Detector power and the output resistor

Please consider the cable length when performing installation in the field. The Prosense detector requires a power supply between 12VDC and 24VDC. Make sure that a minimum 12 VDC supply available at the detector entrance and consider the voltage drop due to cable resistance in case of long distance applications. The maximum loop resistance in the field cable is calculated as follows:

$$R_{loop} = (V_{controller} - V_{detector\ min}) / I_{detector}$$

Example;

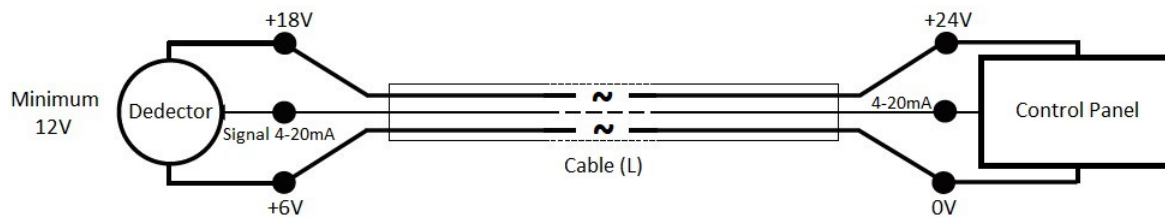

Diagram 5: Field cabling

The controller or power supply is supplying a nominal 24VDC (V controller), the detector minimum allowable voltage is 12VDC (V detector min), therefore the maximum allowable voltage drop between the controller and detector is 12VDC; this means a voltage drop of 6V in each core (V+ core and V- core). Minimum power consumption of the detector without any optional module is 1W. The current required to drive the detector at the minimum voltage is $(I = P / V) \rightarrow 1.0 / 12 = 85\text{mA}$ (I detector).

Maximum power consumption of the detector when optional relay modules installed and all relays are active is 2.5W. The current required to drive the detector at the minimum voltage $(I = P / V) \rightarrow 2.5 / 12 = 210\text{mA}$ (I detector).

So, the maximum field cable loop resistance (R loop) = $12 / 0.21 = 56$ Ohms, or 28 Ohms per core, (allowing for component variations, losses, etc.).

The following tables show the maximum cable distances between the controller and transmitter assuming a voltage drop of 6V in each core and for different cable parameters. The tables are examples only and actual cable parameters and source power supply voltage for the application should be used to calculate the maximum cable distance allowed at the installation site. Typical cable data for detector with relay module:

Cable size (cross sectional area)	Cable type nearest equivalent	Cable resistance Ω/km	Maximum Cable length (L) Meters
0.5mm ²	20AWG	36.8 Ω/km	~500
1.0mm ²	17AWG	19.5 Ω/km	~800
1.5mm ²	16AWG	12.7 Ω/km	~1200
2.0mm ²	14AWG	10.1 Ω/km	~1500
2.5mm ²	13AWG	8.0 Ω/km	~1800

Table 3 : Typical cable details and maximum distance for cabling



If temperature exceeds 70°C at entry or 80°C at branching point use suitably rated cable and cable glands or conductors in conduit.

Cabling

The use of industrial grade shielded field cable is recommended. The best practices shown, screened 3 cores (plus screen 90% coverage), suitably mechanically protected copper cable with a suitable explosion-proof gland, or ¾" NPT steel conduit, depending on the distance between control panel and detector 0.5 to 2.5 mm² (20-13 AWG) conductors can give better results. Ensure the cable gland is installed correctly and fully tightened.

Cable and Earth/Ground Regimes

Effective Earth/Ground bonding is important to ensure good EMC and RFI immunity. The following diagrams show examples of how to earth/ground bond the cable at enclosures. The same principles apply to conduit installations. These bonding techniques provide good RFI/EMC performance. Earth/ground loops must be avoided to prevent the risk of false signal variation. The Earth Screen of the field cable should be "tied to Earth" or connected to Ground at one point only. It is common practise to adopt a STAR EARTH connection regime where all instrumentation Screens are connected at one common point. The Screen at the other end of the cable should be "parked" or terminated into a blank terminal. The Screen at the other end of the cable should be "parked" or terminated into a blank terminal.

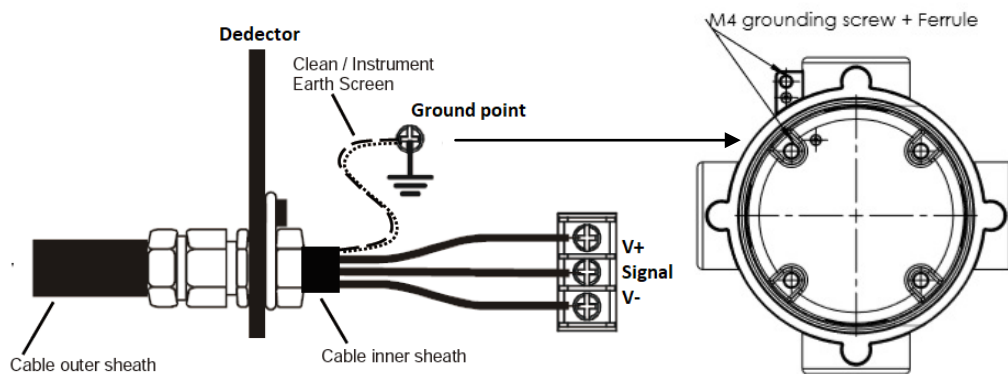

Diagram 6: Grounding

Detector Grounding

Each detector has grounding screw which utilizes grounding for detector main PCB to detector body. The screw should be located correctly and fixed for all times. In case of any maintenance activity this screw should be checked and fixed to make sure for proper grounding. It is recommended to utilize a No 14 AWG copper, (Stranded or Solid), wire. The following diagrams show where to install the wire into the ground screw of the enclosure.

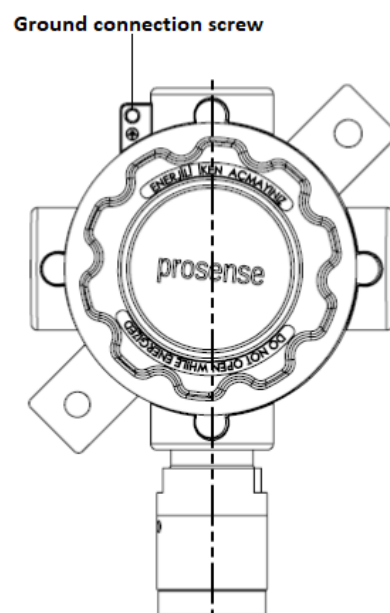

Diagram 7: Detector grounding screw

Default Configuration

Prosense detectors preconfigured to provide signal from analog output depending on the detector and gas type:

Function	Value/Setting	Meaning
Signal output	2.0 mA	Fault
	2.0 mA	Warmup
	3.0 mA	Calibration
	4.0 mA to 20.0 mA	Normal gas measurement
	22.0 mA	Maximum over range

Table 4 : Detector default configuration details

Detector Main board and connection details given in Diagram 8 :

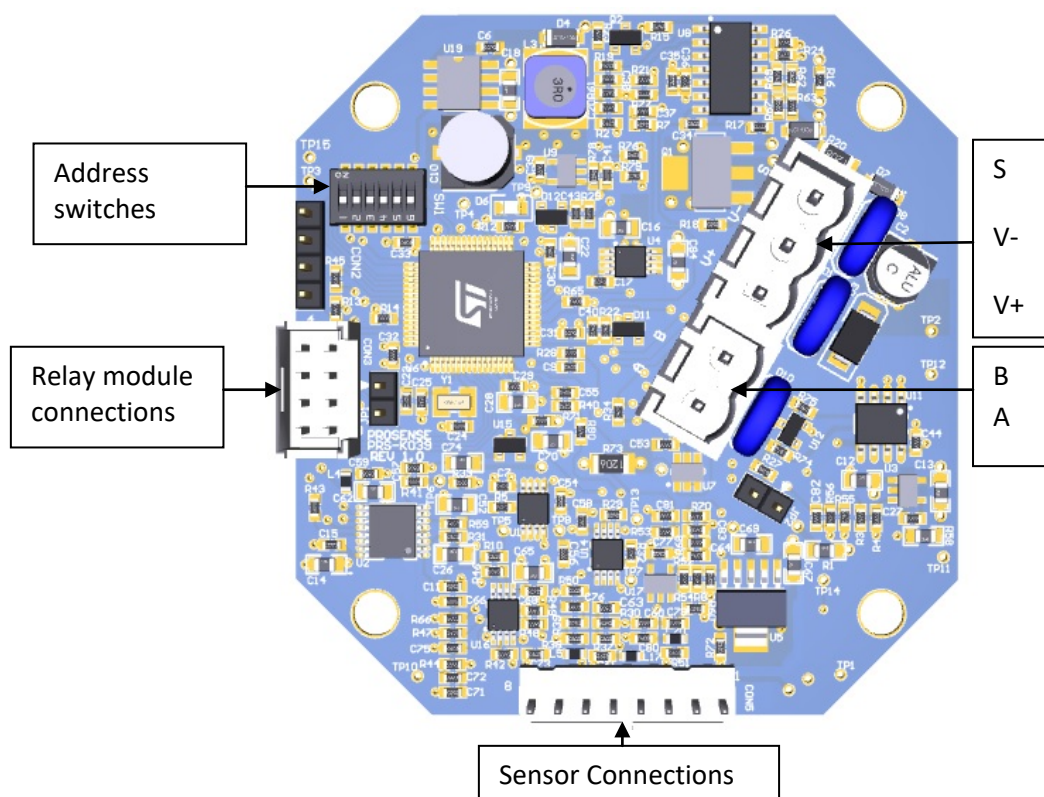

Diagram 8: Detector main board and connections

Detector has integrated RS485 Serial communication devices. Hence both digital and analog outputs are available onboard. Port definitions are given in table6:

Port	Usage
V +	Power input (+) 12VDC – 24VDC
V -	Power input (-) 12VDC – 24VDC
S	Current Output Signal (4mA – 20mA)
A	RS485 Serial communication output port A
B	RS485 Serial communication output port B

Table 5 : Detector output ports and their usage

Detector Configuration

The Prosense dedecor has three different types of connection depending on installed boards:

1. Single 4-20mA output (default option)
2. RS485 Modbus serial communication output
3. 3-Relay outputs

4-20 mA Output:

The default configuration provides single 4-20mA signal output. Prosense detectors can be connected to control panels on the market having 4-20mA input signal. Signal wiring from detector and the control panel should be carried out by shielded cables. Wires cross section depends on the distance between the control panel and the detector. The details given in power cabling are valid as well for signal output. We recommend to use values given in table 4 (see page 13) as cabling best practices.

Please avoid any interruption in case any junctions on wires. The shield is to be grounded from the control panel side only and never connect the shield to the detector. Please make sure clutching or crimping aparats are not loosen or oxidized.

To get the analogue output signal correctly and constant the load resistor on S output should be between 100-500 Ohms. If the load on S port drops below 100 Ohms the detector will behave as the S output is in short circuit status and enable the automatic output saving mode resulting with reducing signal level to 2mA.

Detector RS485 Serial Communication:

Detector has integrated RS485 Serial communication devices. The RS485 communication AB ports are located in another socket. If only RS485 serial communication will be used connection to detector should made by 4 wire that 2 for power (V+, V-) and 2 for RS485 (A,B). If both RS485 Serial communication and analog output will be used then, 5 wire should be used (V+, V-, S, A, B). The total lenght of the connection line should not exceed 800 meters. The wiring for detectors utilized with RS485 board should be done by using connection cable EIA RS485 2 core wires with section 0.22 / 0.35 mm² and shielded. Nominal capacity between the wires < 50pF/m and nominal impedance 120 Ohms.

Detectors will be wired in daisy chain (bus) mode. We recommend not to use star mode connection due to negative impact of interference. Each detector should have unique address number in the chain. The detectors would not be recognised by control panel if same address given to them. Detectors can have addresses between 1 to 63. Address zero(0) is reserved. The address of detector can be adjusted via using DIP-Switch set on the board:

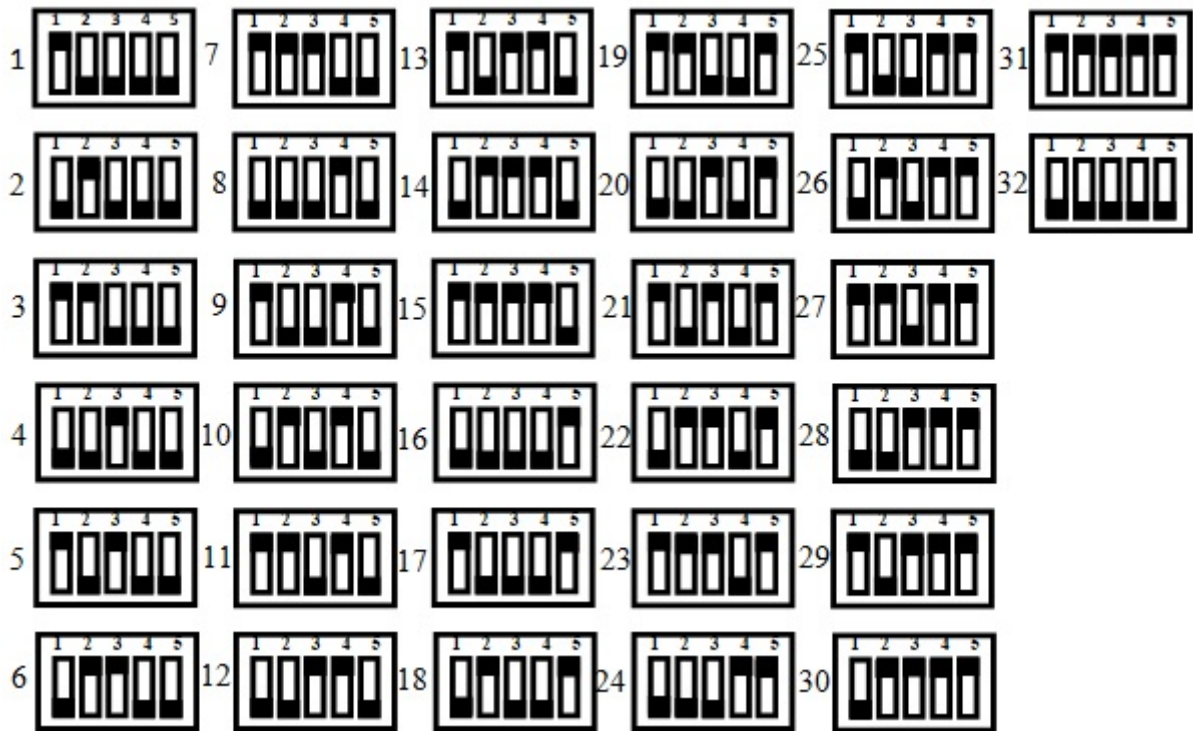

Diagram 9: RS485 Modbus serial communication address and switch position

The last detector in the chain should have 120 Ohms RS485 termination resistor. The resistor is already implemented on the board by default but not activated. User should activate the termination resistor via using the termination pin once the installation completed:

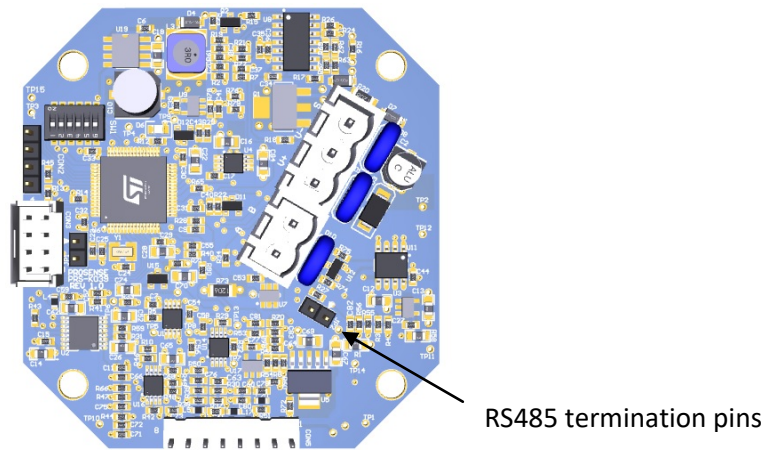

Diagram 10: RS485 Modbus serial communication module end of line jumper

The power connection we recommend to use separate 2 wire cable with specification given earlier in this document (see Electrical Connections section at page11). Once the cabling is completed please check each detector has at least 12 VDC power.

Detector Relay Module:

Prosense provides optional relay modules for Prosense detectors. The relay module details are given below:

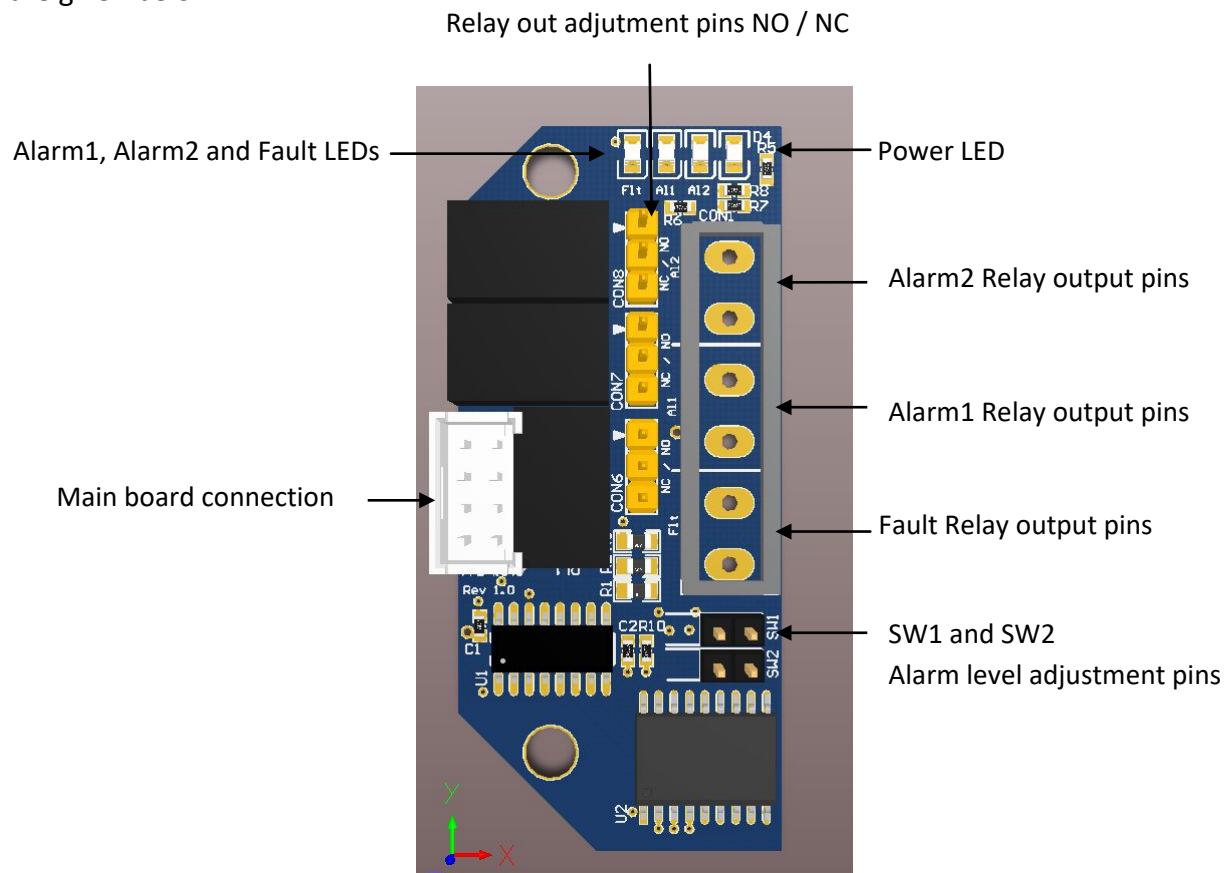

Diagram 11: Relay module

The relay board has 3 relay outputs:

Port	Usage	Energy	Contact
Fault	Fault Relay output	Energised	NO
AI1	Alarm 1 Relay output	Non-Energised	NO
AI2	Alarm 2 Relay output	Non-Energised	NO

Table 6 : Relay module output ports and their usage

All output pins located on Prosense IR detector can be used simultaneously. That means user can use all relay outputs, analog (4-20mA) output and RS485 digital output at same time if implementation equipment allows their usage.

Each relay has 3 pins to adjust how to behave in case of alarm which are

NO : Normally Open

NC : Normally Close

The relay output pin positions shown below:

	Normally Open (NO)
	Normally Close (NC)

Table 7 : Relay output pin positions

The Fault relay is set to NO (Normally Open – Energised) and energised. Hence fault relay LED is always active. It does not mean that there is a fault on detector. If the power LED is active and fault LED is off it means that there is a fault condition on the detector. The fault relay will be de-energised in case of power failure.

The alarm relays set to NO (Normally Open – De-Energised) position at factory.

The alarm levels are also adjustable via using SW1 and SW2 alarm level pins. Alarm levels are defined as percentage in LEL for flammable gases. The alarm levels can be adjusted using jumpers to switch SW1 and SW2. Possible options are given in table 9:

SW1	SW2	Al1 Level (% of full range)	Al2 Level (% of full range)
Open	Open	10 %	15 %
Open	Closed	10 %	20 %
Closed	Closed	20 %	25 %
Closed	Open	20 %	40 %

Table 8: Alarm level pin positions

The alarm levels for toxic gases are defined with the same percentage level of the measurement range as given in the table. For example an Ammonia detector with 0-100 ppm range will provide alert at 10ppm while SW1 and SW2 is open. If the measurement range is 0-300 ppm for the ammonia detector the first alarm will be released at 30ppm.

Oxygen Detectors:

For oxygen detectors the output values and meanings are different as oxygen is naturally available in atmosphere:

Port	Usage	Energy	Contact
Fault	Fault Relay output	Energised	NO
AL1	Alarm 1 Relay output - Lower level for Oxygen	Non-Energised	NO
AL2	Alarm 2 Relay output - Higher level for Oxygen	Non-Energised	NO

Table 9: Realy module output meanings for Oxygen detectors

Alarm levels are also different as given in below table:

SW1	SW2	Al1 Level	Al2 Level
Open	Open	19 %vol	23 %vol
Open	Closed	19 %vol	22 %vol
Closed	Closed	18 %vol	22 %vol
Closed	Open	18 %vol	23 %vol

Table 10: Alarm level (% Vol) pin positions for Oxygen detectors

System Status

The Prosense IR detectors has one LED on main board to show actual status of the detector. In normal conditions while detector works properly the LED blinks with 1 second period (one blink in a second). If detector is in fault condition LED illuminates with 250 ms period (four blinks in a second) and the detector analog output gives 2mA on S port. If detector could not get enough power (lower than 12 VDC) it will also raise fault status.

First Time Switch On (Commissioning)

WARNING

The following procedure requires the detector Cover to be removed while carrying out supply voltage checks. Therefore the appropriate permits to work should be sought in preparation.

Prior to carrying out any HOT WORK ensure local and site procedures are followed.

Ensure that the associated control panel output actuation is inhibited so as to prevent false alarms.

Caution: The following procedure should be followed carefully and only performed by suitably trained personnel

1. Remove the detector cover
2. Configure the detector's analogue output signal and power input connections done correctly
3. Check that all electrical connections are terminated correctly
4. Switch On the external power supply to feed the detector
5. Using a Digital Multi Meter (DMM), check the Supply Voltage at the terminals V+ (24V) and V- (0V), this should be a minimum supply voltage of 12VDC (Maximum supply voltage is 24VDC)
6. Check LED status on detector main board. LED will be luminated right after appying power.
7. Wait two minutes and confirm that LED blinking with one second period.
8. Switch Off the external power to the detector.
9. Fit the cover and make sure non of the cables cause an obstruction while fitting cover
10. Switch on external power to the detector.

Calibration

It is recommended to periodically carry out calibration to ensure correct operation. Prosense P series detector calibration includes two steps as zero and span calibration. It is possible to perform each step independently. Prosense recommends to perform both calibration steps to have correct calibration. Detector should be powered and stabilized for at least 4 hours before calibration. During the calibration phases the detector output is inhibited (default 3mA) to avoid false alarms. Zero calibration of infrared sensors should be done with N₂ and zero calibration of other sensors should be done with zero air (O₂ and N₂ gas mixtures). For Flammable gas calibration use a calibration gas concentration of between 25%LEL and 75%LEL to ensure that the required accuracy can be attained. It is necessary to use international traceable gases.

To calibrate the detector, use an appropriate span gas cylinder, constant flow regulator and Prosense Gas Cap. The flow rates used for calibration gas must be 0.5 l/min.

Calibration procedure may vary depending on the Prosense detector model. If Prosense Gas Monitor software available for calibration, first enable communication between detector and computer via setting the first address switch to ON position. Then give clean air (N₂ for IR sensors) gas to sensor head to perform zero. It would be better to follow the ADC value in graph to see and make sure sensor has been stabilized. Then press "Set Zero" button to start zeroing. Detector will automatically set the zero level. Apply the span gas immediately after zero calibration. Gas concentration may vary depending of the gas and sensor type. For flammable gases with Pellistor and Catalytic sensors 30LEL methane stabilized with clean air; for flammable gases with IR sensors 50LEL methane gas stabilized with N₂ should be used. Apply the gas to the sensor and wait at least 2 minutes. Also monitor ADC value on graph to make sure sensor reading has been stabilized. Then press "Set Span" button to start span calibration. It is necessary to continue applying gas while detector automatically sets the span level. It may take another two minutes to complete. For more information please see the Prosense Gas Monitor software user guide.

If Prosense Gas monitor software is not available follow below procedure step by step. Otherwise the calibration would not be completed and non of the values recorded.

- 1- Put detector in calibration mode. To enable calibration mode the last switch on address switch board should set to ON. If it was OFF it should need to set to ON. If it was already ON it should need to set first OFF, then 10 seconds later set to ON.
- 2- Apply zero gas (clean air or N₂ depending of the detector and sensor type) to the sensor for zeroing. The LED on main board will solid for 60 seconds and than it will return to normal speed (1 second period). Once LED returned to normal flashing speed zeroing is completed.
- 3- Apply span gas and wait 60 seconds.
- 4- Set last switch to OFF position to start span calibration.

- 5- Detector will set span level automatically. The LED on main board will solid for 60 seconds and then it will return to normal speed (1 second period). Once LED returned to normal flashing speed span calibration is completed.

It is possible to perform only zero or only span calibration. It is recommended to perform both calibration steps. Analog output will set to 3mA level during calibration steps performed, alarms and fault status or relays will be deactivated. If you want to monitor analog output via using a multimeter you must use a resistor (~200 Ohms) while serially connecting the multimeter to the S port. Otherwise detector will behave as S analog output port has been shorted hence it will enable safety mode and set output level to 2mA.

Maintenance

Proactive maintenance:

All gas detectors including both for flammable and toxic gases should have to pass a functional test and calibration every three to twelve months according to EN 60079-29-2 industrial standards. The test results and calibration reports should be recorded in maintenance books.

Operational Life:

Catalytic flammable gas sensor made by using the pellistors that suffer from a loss of sensitivity when in the presence of poisons or inhibitors, e.g. silicones, sulphides, chlorine, lead or halogenated hydrocarbons. The pellistors are poison resistant to maximize the operational life of the Catalytic flammable sensor. A typical operating life, subject to the presence of poisons/inhibitors is 48-60 months. The infrared flammable gas sensor is not affected by the mentioned poisons and has a longer life span.

Typical life of a toxic gas sensor which made by electrochemical component is dependent on the application, frequency and amount of gas exposure. Under normal conditions (visual inspection in 3 months period and test/recalibration in 6 months period), the Prosense Oxygen and other toxic sensors have an expected life equal to or greater than 24 months.

Servicing

Important: All replacement actions (sensor, sinter, and sensor head) shall be done by Prosense service personnel as it needs special steps that should be performed in laboratory environment.

Sensor replacement:

The Flammable Catalytic and Toxic ECC cells that are used with the Prosense Sensor Head have no serviceable parts. When they have reached the end of their operational life, simply replace the cell.

Pellistor sensor replacement:

Due to current technical design pellistor sensors are not replaceable in the field. The whole sensor head assembly must be replaced once the pellistor sensor has reached end of its life or in case of any failure.

Electrochemical sensor:

The electrochemical sensors are mounted to sensor electronic module inside the sensor head and it is possible to perform replacement in the field. Once replacement sensor on hand follow the steps given below:

- 1- Power-off the detector via disconnecting power cable from control panel or supply
- 2- Use allen key nr3 to loosen locking grub screw on sensor head
- 3- Remove the sensor head cap
- 4- Check the sinter and if it blocks the air ventilation replace the sinter via steps given in "Sinter Replacement" section.
- 5- Remove electrochemical sensor from sensor module.
- 6- Check sensor electronic module. Some EEC sensors might leak to the sensor PCB and create unreparable hazard on PCB. The whole sensor head must be replaced if there is any chemical leakage on sensor PCB.
- 7- Install the new sensor in to sensor PCB.
- 8- Install the sensor head cab and fix the locking grub screw.
- 9- Power-on the detector and wait at least 4 hours
- 10- Perform full calibration.

Infrared Sensor:

The NDIR sensors are mounted to sensor electronic module (sensor PCB) inside the sensor head and it is possible to perform replacement in the field. Once replacement sensor on hand follow the steps given below:

- 1- Power-off the detector via disconnecting power cable from control panel or supply
- 2- Use allen key nr3 to loosen locking grub screw on sensor head
- 3- Remove the sensor head cap
- 4- Check the sinter and if it blocks the air ventilation replace the sinter via steps given in "Sinter Replacement" section.
- 5- Remove NDIR sensor from sensor module.
- 6- Install the new sensor into sensor PCB.
- 7- Install the sensor head cab and fix the locking grub screw.
- 8- Power-on the detector and wait at least 30 minutes
- 9- Perform full calibration.

Sensor PCB replacement:

Due to current technical design restrictions sensors PCBs are not replaceable in the field. The whole sensor head assembly must be replaced once the sensor PCB damaged or in case of any failure.

Sinter replacement:

Due to environmental conditions the metal filter - sinter at sensor head might lost permeability that could negative impact on sensor performance. For example if the installation includes cement or similar dust the sinter would be block the air/gas entry to sensor. The sinter should be checked visually and replaced if necessary. The sinter is located inside the sensor head cap and sensor head cap must be replaced when sinter needs replacement. To replace sinter please check diagram-2 and follow the below procedure:

- 1- Power off the detector via disconnecting power cable from control panel or supply
- 2- Loosen the locking grub screw via allen key nr3
- 3- Unscrew the sensor head cap that holds the dirty sinter
- 4- Remove the sinter holder via using two holes on it
- 5- Remove the old sinter
- 6- Install new sinter to its location, make sure sinter located correctly to designed area
- 7- Install sinter holder and fix completely to hold sinter to go back
- 8- Screw the sensor head cap including the clean sinter
- 9- Fix the Locking grub screw

Sensor head replacement:

Prosense sensor head is a separate part that can be replaced. The sensor head includes integrated sensor, electronic device and sinter in it. PQ series sensor head is pre-calibrated and will start function immediately following the replacement. To replace sensor head:

- 1- Power-Off the detector via disconnecting power cable from control panel or supply
- 2- Open the detector cover
- 3- Disconnect sensor cables from the detector main board
- 4- Remove the sensor head from the body via using Nr 38 wrench key.
- 5- Install sensor head
- 6- Sensor head must be fixed to enclosure with 20Nm toque
- 7- Connect the sensor cables to detector main board
- 8- Close the detector cover
- 9- Power-On Prosense detector
- 10- Leave detector working at least 4 hours in clean air environment
- 11- Check detector calibration.

Detector Transmitter board replacement:

Prosense detector transmitter is the main logic board including all definitions and configuration. Hence it is necessary to perform reconfiguration in case of replacement. Hence the spare part must be ordered by giving the serial number of the detector. The replacement should be done via following steps:

- 1- Power-Off the detector via disconnecting power cable from control panel or supply
- 2- Open the detector cover
- 3- Disconnect sensor, display, power and other external interface cables from the detector main board
- 4- Remove the screws mounting the board to enclosure.
- 5- Remove the board
- 6- Install new board and fix via putting screws
- 7- Install sensor and display cables
- 8- Install power and other external interface cables
- 9- Power-on detector and check the LEDs according to steps given in “Commissioning” section
- 10- Leave detector working at least 4 hours in clean air environment
- 11- Check detector calibration.

Detector Relay Module replacement:

Prosense relay module is a replaceable part. The replacement should be done via following steps:

- 1- Power-Off the detector via disconnecting power cable from control panel or supply
- 2- Open the detector cover
- 3- Remove relay module output connections
- 4- Remove screws fixing the relay module
- 5- Remove relay module.
- 6- Install relay module while taking care to connectors directly on main board socket.
- 7- Put the screws to fix the relay module
- 8- Perform any adjustment necessary about alarm levels and relay operating modes.
- 9- Install relay module output connections
- 10- Close the detector cover
- 11- Power-On detector
- 12- Check detector and relay settings and adjust if necessary.

Spare Parts

Product Code	Description
PY-04S-05	Pellistor Sensor Head, 0-100 %LEL
PY-04S-03	Infrared Sensor Head, 0-100 %LEL
PY-04S-36	Hydrogen Sensor Head, 0-500 ppm
PY-04S-36B	Hydrogen Sensor Head, 0-1000 ppm
PY-04S-36C	Hydrogen Sensor Head, 0-2000 ppm
PY-04S-44	Carbon monoxide Sensor Head, 0-300 ppm
PY-04S-44B	Carbon monoxide Sensor Head, 0-500 ppm
PY-04S-44C	Carbon monoxide Sensor Head, 0-1000 ppm
PY-04S-48	Ammonia Sensor Head, 0-100 ppm
PY-04S-48B	Ammonia Sensor Head, 0-1000 ppm
PY-04S-60	Acetylene Sensor Head, 0-100 %LEL
PY-04S-62	Ethylene Oxide(ETO) Sensor Head, 0-20 ppm
PY-04S-62B	Ethylene Oxide(ETO) Sensor Head, 0-100 ppm, 1 Year
PY-04S-64	Hydrogen Sulfide(H ₂ S) Sensor Head, 0-100 ppm
PY-04S-64B	Hydrogen Sulfide(H ₂ S) Sensor Head, 0-500 ppm
PY-04S-65	Oxygen Sensor Head, 0-25% vol
PY-04S-66	Sulfide Dioxide Sensor Head, 0-10 ppm
PY-04S-67	Nitric Oxide Sensor Head, 0-250 ppm
PY-04S-68	Nitrogen Dioxide Sensor Head, 0-30 ppm
PY-04S-69	Chlorine Sensor Head, 0-10 ppm
PY-04S-71	Carbondioxide Sensor Head, 0-5000 ppm
PY-04S-71B	Carbondioxide Sensor Head, 0-5% Vol
PY-04S-72	Freon Sensor Head, 0-2000 ppm
PY-04S-74	Formaldehyde Sensor Head, 0-10 ppm
PY-04B	P Series Enclosure
UPY-04T	P Series Transmitter
UPY-04S-03	P Series Infrared Sensor, 0-100 %LEL
UPY-04S-05	P Series Pellistor Sensor, 0-100 %LEL
UPY-04S-44	P Series Carbon Monoxide Sensor, 0-300 Ppm
UPY-04S-44B	P Series Carbon Monoxide Sensor, 0-500 ppm
UPY-04S-44C	P Series Carbon Monoxide Sensor, 0-1000 ppm
UPY-04S-48	P Series Ammonia Sensor, 0-100 ppm
UPY-04S-48B	P Series Ammonia Sensor, 0-100 ppm
UPY-04S-60	P Series Acetylene Pellistor Sensor, 0-100 %LEL

UPY-04S-62	P Series ETO Sensor, 0-20 Ppm
UPY-04S-62B	P Series ETO Sensor, 0-100 Ppm
UPY-04S-64	P Series Hydrogen Sulfide Sensor, 0-100 Ppm
UPY-04S-64B	P Series Hydrogen Sulfide Sensor, 0-500 Ppm
UPY-04S-65	P Series Oxygene Sensor, 0-25% Vol
UPY-04S-66	P Series Sulfur Dioxide Sensor, 0-10 Ppm
UPY-04S-67	P Series Nitric Oxide Sensor , 0-250 Ppm
UPY-04S-68	P Series Nitrogen Dioxide Sensor, 0-30 Ppm
UPY-04S-69	P Series Chlorine Dioxide Sensor, 0-10 Ppm
UPY-04S-71	P Series Carbon Dioxide Sensor, 0-5000 Ppm
UPY-04S-71B	P Series Carbon Dioxide Sensor, 0-5% Vol
UPY-04S-72	P Series Refrigerant (Freon) Sensor, 0-2000 Ppm
UPY-04S-74	P Series Formaldehyde Sensor, 0-10 Ppm
UPY-04S-75	P Series Hydrogen Cyanide Sensor, 0-25 Ppm
UPY-04S-76	P Series Hydrogen Peroxide Sensor, 0-300 Ppm

General Specification

Use:

3-wire, 4-20mA analog and 2 wire RS485 digital gas detector transmitter for use with directly installed flammable gas sensors. For the protection of personnel and plant from flammable gas hazards.

Electrical Specifications:

Input Voltage Range	12 to 24VDC (24VDC nominal)
Max Power Consumption	Max 2.5 Watts. at 24VDC
Current output	4-20mA
2.0 mA	Fault
4.0 mA to 20.0 mA	Normal gas measurement
2.0 mA	Inhibit (during configuration/warming)
3.0 mA	Calibration
22.0 mA	Maximum over range
Terminals	3 x screw terminals suitable for wire diameter 0.5mm ² to 2.5mm ² (20AWG to 13AWG) for power input and analog(4-20mA) output, 2 x screw terminals suitable for wire diameter 0.5mm ² to 2.5mm ² (20AWG to 13AWG) for RS485 digital output
Relays	3 x (1A 30VDC, 0.5A 125VAC, 0.3A 80VDC). Selectable normally open or normally closed (switch). Alarm relays de-energised and fault relay energised.
Communication	RS485, Modbus RTU

Table 12: Electrical specifications

Detector Body Specifications:

Material	Epoxy painted aluminium alloy
Weight	Aluminium Alloy: 1.4kg (with Sensor Header)
Mounting	Wall mounting
Entries	2 x ½ NPT field cable entries, ¾ NPT sensor entry

Table 13: Detector body specifications

Environmental:

IP Rating	IP65 in accordance with EN60529:1992
Operating Temperature	-40°C to +70°C / -40°F to +158°F
Operating Humidity	Continuous 20-90%RH (non condensing) Intermittent 10-99%RH (non condensing)
Operating Pressure	90-110kPa
Storage Conditions	-30°C to +70°C (-22°F to +158°F)

Table 14: Environmental specifications

Safety instruction for hazardous area installation

Prosense P and PE series gas detectors are projected and built according to ATEX Directive 2014/34/EU with reference to standard EN 60079-0, EN 60079-1. "ATEX", by the French "ATmosphere EXplosible", provides the technical requirements to be applied to equipment intended for use in potentially explosive atmospheres. The scope of directive is to remove technical barriers to trade between Member States of the European Community. The Prosense P and PE series gas detectors must be installed and maintenance according to the suitable standards for electrical application in potentially explosive atmospheres (example: EN 60079-14, EN 60079-17 or other national standards).

Read this instruction first and keep this instruction manual always available.

The following instructions apply to equipment covered by ATEX certificate number:

1. Prosense P and PE series gas detectors may be installed in hazardous area with flammable gases, vapors, and mist, group II, category 2G, maximum superficial permissible temperature 70°C.

Device category 2G, Identification II 2G

Ex db IIC T4 Gb (Tamb = -40÷+70 °C or -40÷+50 °C)

Ex db IIC T5 Gb (Tamb = -40÷+40 °C)

It means:  (European Community logo for ATEX applications) – group II (potentially explosive atmospheres – surface application – OTHER than mines)

Category 2G (G => Gas) – Zone 1 and Zone 21

Ex db => protection mode: explosion proof enclosure

IIC => define kind of gases

T4 Gb (Tamb = -40÷+70 °C or -40÷+50 °C)

T5 Gb (Tamb = -40÷+40 °C) => Temperature class -- Maximum allowable surface temperature.

IP 65 => Mechanical protection degree – protection against solid, dust and liquid.

2. Suitably trained personnel shall carry out installation in accordance with applicable code practice.

3. The electrical devices must be grounded using their grounding connections. The grounding connection must be ATEX certified, suitable for the application required, substances, maximum superficial temperature, ambient temperature.

4. The user should guarantee periodical cleaning of the places where dust can storage to avoid the piling up to 5 mm.

5. The user should not repair this equipment.

6. The user should guarantee the keeping of the safety characteristic of the device after maintenance of repairing.

7. If the equipment is likely to come into contact with aggressive substances, it is responsibility of the user to take suitable precautions that prevent it from being adversely affected, thus ensuring that the type of protection is not compromised.

Aggressive substances: example Acids, liquid, gases with can affected metals

8. To guarantee the respect of the protection degree cable glands, blanking elements and thread adapters shall be certified Ex components according to protection "d" and a blanking element shall not be used with an adapter.

9. Sinter replacement shall be done by an approved technical service personal according to P series and PE series user manual "Sinter replacement" procedure (PRS-UM-P-EN and PRS-UM-PE).

10. O-ring is made of Silicone and continuous operating temperature is -50C to 105C

11. If temperature exceeds 70°C at entry or 80°C at branching point use suitably rated cable and cable glands or conductors in conduit.
12. Thickness of outer painting is between 40 µm – 80 µm.
13. Maximum power consumption of the detector with optional boards installed is $P_{max}=2.5W$ where $I_{max}=100mA$ and $V_{max}=24VDC$.
14. All electrical connections should be made in accordance with any relevant local or national legislation, standards or codes of practice. Prosense detectors can operate between 12 - 24 VDC.
15. The use of industrial grade, suitably shielded field cable is recommended. The best practices shown that, screened 3 cores (plus screen 90% coverage), suitably mechanically protected copper cable with a suitable explosion-proof gland, or ¾" NPT steel conduit, depending on the distance between signal received or control panel and detector 0.5 to 2.5 mm² (20 to 13 AWG) conductors can give better results. Ensure the cable gland is installed correctly and fully tightened.
16. Effective Earth/Ground bonding is important to ensure good EMC and RFI immunity. The Earth Screen of the field cable should be "tied to Earth" or connected to Ground at one point only. It is common practise to adopt a STAR EARTH connection regime where all instrumentation Screens are connected at one common point. The Screen at the other end of the cable should be "parked" or terminated into a blank terminal.
17. Each detector has grounding screw which utilizes grounding for detector main PCB to detector body. The screw should be located correctly and fixed for all times. In case of any maintenance activity this screw should be checked and fixed to make sure for proper grounding. It is recommended to utilize a No 14 AWG copper, (Stranded or Solid), wire.



[1] EU-TYPE EXAMINATION CERTIFICATE

[2] Equipment or Protective System intended for use in potentially explosive atmospheres - Directive 2014/34/EU Annex III - MODULE B: EU-TYPE EXAMINATION

[3] EU-type Examination Certificate number: **IMQ 19 ATEX 045 X**

[4] **PRODUCT:** Gas detector
TYPE/SERIES: P**** and P****PE Series

[5] **MANUFACTURER:** Prosense Teknoloji San. Ltd. Şti.

[6] **ADDRESS:** Yukari M. Harman Sokak No. 42 – TR-Kartal Istanbul

[7] This equipment and any acceptable variation thereto are specified in the annex to this certificate and the documents therein referred to.

[8] IMQ, notified body N° 0051, in accordance with Article 17 of Directive 2014/34/EU of the European Parliament and of the Council, dated 26 February 2014, certifies that this product has been found to comply with the Essential Health and Safety Requirements relating to the design and construction of equipment and protective systems intended for use in potentially explosive atmospheres given in Annex II to the Directive.

The examination and test results are recorded in Report No.:

AT19-0035328-01

[9] Compliance with Essential Health and Safety Requirements, except in respect of those listed at item 18 of the annex, has been assured by compliance with:

EN 60079-0:2018; EN 60079-1:2014

[10] If the sign "X" is placed after the certificate number, it indicates that the equipment or protective system is subject to special conditions for safe use specified in the schedule to this certificate

[11] This EU - TYPE EXAMINATION CERTIFICATE relates only to the design and construction of the specified product. Further requirements of the Directive apply to the manufacturing process and supply of this product. These are not covered by this certificate.

[12] The marking of the equipment or protective system shall include the following:

II 2G Ex db IIC T5/T4 Gb

This document is composed of 4 pages including 1 annex

FIRST ISSUE: 2019 | 10 | 17

CURRENT ISSUE: 2019 | 10 | 17

PREVIOUS ISSUE: -

B.U. PRODUCT CONFORMITY ASSESSMENT
CERTIFICATION SECTOR – MANAGER

This Certificate may only be reproduced in its entirety and without any change. It is subject to the general rules for assessing conformity to community Directives for which IMQ operates as Notified Body and to the particular rules for the aforementioned Directive.



PRD N° 005 B

Member of the Accredited Bodies
International ILAC, APAC, IAF
Member of the Accredited Bodies
Member of the Accredited Bodies



[13] **Annex**

[14] EU-type Examination Certificate number: **IMQ 19 ATEX 045 X**

[15.6] **Warnings:** -

[14] **Report:** AT19-0035328-01

[14.1] **Routine (factory) tests:**

The manufacturer shall carry out the routine test prescribed at clause 27 of the EN 60079-0.

[14.2] **Conformity with the documentation:**

The manufacturer shall carry out the verifications or tests necessary to ensure that the product complies with the documentation.

Marking the equipment in accordance with Clause 29 of EN 60079-0, the manufacturer attests on his own responsibility that:

- the equipment has been constructed in accordance with the applicable requirements of the relevant standards in safety matters;
- the routine verifications and routine tests in 28.1 of EN 60079-0 have been successfully completed with positive results.

[14.3] **Installation conditions:**

Above referred equipment is foreseen to be installed in locations where there are environmental conditions as clearly specified at clause 1, par. 2 of EN 60079-0.

Installation and use in atmospheric and environmental conditions that are out of above mentioned intervals require special considerations and additional measures by the side of installer or user. These should be specified to the manufacturer by the user.

It is not required by applicable standard listed in [9] that the certification body confirm suitability for the adverse conditions.

This equipment shall be installed and maintained according to installation and maintenance standards EN 60079-14 and EN 60079-17, and strictly in compliance with details listed in manufacturer's use and safety instructions.

[17] **Special Condition of use (X):**

P**** and **P****PE** Series gas detectors must be installed only with sensor head pointing downwards.

Cable glands and thread adapters used for entry into the enclosure, as well as blanking elements, shall be certified as Ex Components according to protection "d", and suitable for the ambient temperature range specified above.

Electrical components/devices installed inside the junction box must not exceed a total power consumption of 2,5 W in order to ensure compliance with the declared maximum temperature rise.

Sinter disc and sensor head cap is considered a mounting component and must be replaced as a single unit.

Mod. 3686/4



PRD N° 005 B

Membro degli Accordi di Muto Riconoscimento (EA, UK e SAC) Signatory of EA, UK and SAC Mutual Recognition Agreements



[13] Annex

[14] EU-type Examination Certificate number: **IMQ 19 ATEX 045 X**

[18] **Essential Health and safety Requirements:**
This Certificate **does not** indicate compliance with electrical safety and performance requirements other than those expressly included in the Standards listed in [9].
This Certificate **does not** cover hazards coming from environmental conditions different from those clearly and precisely indicated and covered in clause 1 of EN 60079-0.

ESHR 1.2.7 According Annex VII of the Directive

ESHR 1.4 Not verified.

ESHR 1.5 Not verified.

ESHR 3 Not applied.

In addition to the Essential Health and Safety Requirements (EHSRs) covered by the standards listed at [9], the following are considered relevant to this product, and conformity is demonstrated in the report:
None

[19] **Descriptive documents:** DL-AT19-0035328-01, rev. 0, dated 2019-08-07.

[20] **Certification Validity Conditions:**

The use of this Certificate is subject to the Certification Scheme and to the Regulation applicable to holders of IMQ Certificates.

The validity of this certificate is subject to the condition that the manufacturer complies with the results of the document review and of the pertinent requirement if any included, recorded in the relevant copy of documentation as per 19.

One copy of the mentioned documentation is kept in IMQ file.

[21] **Variations**

First issue.

Declaration





Manufacturer Declaration of Conformity



Prosense Teknoloji San Ltd. Şti declares the P and PE Series products to be in accordance with the following standards and directives.

Name and address of Manufacturer: **Prosense Teknoloji San Ltd Şti**
Cumhuriyet Mah. Mermer Sok No:16
34876 -Kartal – İstanbul – Türkiye

Description of Devices: P and PE Series Fixed Type Gas Detectors

Ex Designation:  II 2G Ex db IIC T5 Gb ;  II 2G Ex db IIC T6 Gb

Applied Harmonized international standards:

EN 60079-0:2018 Equipment – General requirements
EN 60079-1:2014 Equipment protection by flameproof enclosures 'd'
EN 50270:2015 Electromagnetic compatibility - Electrical apparatus for the detection and measurement of combustible gases, toxic gases and oxygen

Applied European Directives:

2014/34/EU ATEX Directive
2014/30/EU Electromagnetic Compatibility (EMC) Directive

Each P and PE Series gas detector device which the Production Quality Assurance procedures and Type Examination procedures have been applied has been shown to conform to an approved Type and to the applicable classification rules and essential principles before being supplied. This declaration is being made on the basis of the following certificates:

Production Quality Assurance Certificate: ExVeritas 18PQAN0072

Type Examination Certificate: IMQ19 ATEX 045 X
IEP 12 ATEX 082

Authorised Signatory: **Firat Celep**
Production Manager

Date: **26.02.2020**

Warranty Statement

All products are designed and manufactured to the latest internationally recognized standards by Prosense Technology under a Quality Management system that is certified to ISO 9001. As such Prosense Technology warrants its products against defective parts and workmanship and will repair or (at its option) replace any instruments which are or may become defective under proper use within 12 months from date of commissioning by an approved Prosense Technology representative or 18 months from date of shipment from Prosense Technology, whichever is the sooner. This warranty does not cover disposable batteries or damage caused by accident, abuse, abnormal operating conditions or poisoning of sensor.

Defective goods must be returned to Prosense Technology premises accompanied by a detailed description of any issue. Where return of goods is not practicable Prosense Technology reserves the right to charge for any site attendance where any fault is not found with the equipment. Prosense Technology shall not be liable for any loss or damage whatsoever or howsoever occasioned which may be a direct or indirect result of the use or operation of the Contract Goods by the Buyer or any Party.

This warranty covers instrument and parts sold to the Buyer only by authorized distributors, dealers and representatives as appointed by Prosense Technology. The warranties set out in this clause are not pro rata, i.e. the initial warranty period is not extended by virtue of any works carried out there under.

In no event will Prosense Technology be liable for any incidental damages, consequential damages, special damages, punitive damages, statutory damages, indirect damages, loss of profits, loss of revenues, or loss of use, even if informed of the possibility of such damages. Prosense Technology's liability for any claims arising out of or related to this product will in no case exceed the order value. To the extent permitted by applicable law, these limitations and exclusions will apply regardless of whether liability arises from breach of contract, warranty, tort (including but not limited to negligence), by operation of law, or otherwise.