



PROSENSE BTN Series Gas Detectors Installation and User Manual

WARNING!

This manual must be carefully read by all persons who have or will have the responsibility for installing, using or servicing this product.

Like any equipment, this product will perform as designed only if installed, used and serviced in accordance with the manufacturer's instructions. Otherwise, it could fail to perform as designed and persons who rely on this product for their safety could suffer severe personal injury or death.

The warranties made by Prosense with respect to this product are voided if the product is not installed, used and serviced in accordance with the instructions in this user guide. Please protect yourself and other by following them.

Important Remark

The detector has been factory-tested before delivery, the commissioning after installation must include the zero- and span-adjustment. The commissioning has to be terminated by a function test of the complete gas detection system.

CONTENTS

For Your Safety 4

 Strictly Follow The Instructions For Use..... 4

 Use in Areas Subject to Explosion Hazards 4

 Liability For Proper Function or Damage..... 4

 Intended Use 4

Introduction..... 6

Detector Body..... 6

Sensor Head..... 7

Installation 7

Mounting The Detector 8

Cabling and Connections 9

BTN Series Detectors Connections 10

BTN Series Detectors Connections with RS485 Module 12

System Status 13

General Specification 15

Warranty Statement..... 16

For Your Safety

Ensure that this Operating Manual is read and understood **BEFORE** installing / operating / maintaining the equipment. Pay particular attention to Warnings and Cautions. All document Warnings are listed here and repeated where appropriate at the start of the relevant chapter(s) of this Operating Manual. Cautions appear in the sections/sub-sections of the document where they apply.

Strictly Follow The Instructions for Use

Any use of the detectors requires full understanding and strict observation of these instructions. The detector is only to be used for purposes specified here.

Use In Areas Subject To Explosion Hazards

Equipment or components which are used in potentially explosive atmospheres and have been tested and approved according to International or European regulations may be used only under the conditions specified here. Modifications of components or the use of faulty or incomplete parts are not permitted. In case of repairs of equipment or components, the national regulations must be observed.

Liability For Proper Function Or Damage

The liability for the proper function of the detector is irrevocably transferred to the owner or operator to the extent that the detector is serviced or repaired by personnel not employed or authorized by Prosense or if the sensing head is used in a manner not conforming to its intended use. Prosense cannot be held responsible for damage caused by non-compliance with the recommendations given above. The warranty and liability provisions of the terms of sale and delivery of Prosense are likewise not modified by the recommendations given above.

Intended Use

The BTN series detectors are intended to be used for stationary, continuous monitoring for combustible gas/air or vapour/air mixtures below the Lower Explosion Limit (LEL) resp. below 10 % of the LEL under atmospheric conditions. BTN Series detectors are suitable to use in safe areas.

Not to be used in oxygen enriched atmospheres

In conjunction with the central controllers Prosense detectors with preadjusted alarm thresholds audible and visible alarm devices or automatic countermeasures can be activated before the detected gases or vapours can form dangerous flammable mixtures with air.

Please be alerted in following special conditions may have impact on measuring function due to the nature of measuring method:

1. Very High Gas Concentrations

Catalytic and Pellistor sensors used to detect flammable and toxic gases. The measuring method based on heat produced by reaction on the catalytic oxidation of a flammable gas. In

case of high gas concentrations there is not enough oxygen in the sensor to perform oxidation process correctly. Hence the measuring signal decreases at high gas concentrations and even can lead to measuring signal within the measuring range again. A connected controller must be operated with alarm devices, outputs, and alarm thresholds operating as latched if the measuring range is exceeded. In this case do not reset latching alarms without having ensured a safe condition by means of an independent gas concentrations measurement.

2. Minimum Oxygen Concentration

The measuring principle of heat of reaction needs a minimum oxygen concentration of 12 % by vol., otherwise the measuring values will be too low because of oxygen deficiency.

3. Long-term Gassing With Methane At Very Low Temperatures

If the Prosense BTN series detectors are operated applying with methane at very low temperatures, the measuring signal at longterm exposition may decrease after alarm activation and may lead to misinterpretation.

If a gas alarm occurs, necessary actions need to be taken immediately. The decrease of the measuring signal should not mean that the gas concentration has been decreased. We recommend to keep alarms on the associated controllers and not to reset these alarms without performing measurement with an independent gas detectors to make sure conditions are safe.

Introduction

The Prosense comprises a gas detector body and a choice of sensors heads for detecting flammable gas, toxic gas and oxygen. The construction of Prosense allows it to be used in non-hazardous safe area locations.

Prosense detectors can be configured with a wide range of different sensors may be used to detect a broader range of target gases. The detector provides three programmable relays which are FAULT, ALARM1 and ALARM2 for controlling external equipment e.g. alarms, sirens, valves or switches. The detector can be configured to communicate RS485 modbus protocol with an optional module and also provides FAULT and ALARM1 relay outputs at same time.

Detector Body

Prosense BTN series detectors comprises of the main parts as shown below:

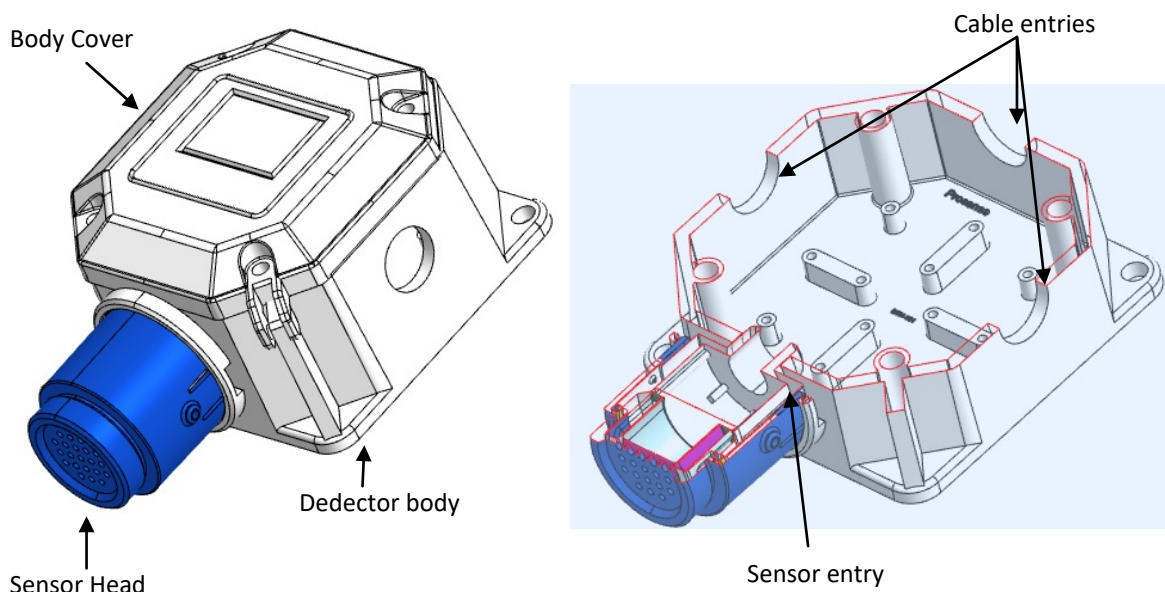

Diagram 1: Exploded view

The detector enclosure has four threaded entries. The three cable entries either side of the upper part of the transmitter housing are for connecting the power source, signal output and relay contacts to associated signalling equipment. The bottom entry allows direct connection of the sensor socket. The body has integrated mounting screw locations on housing.

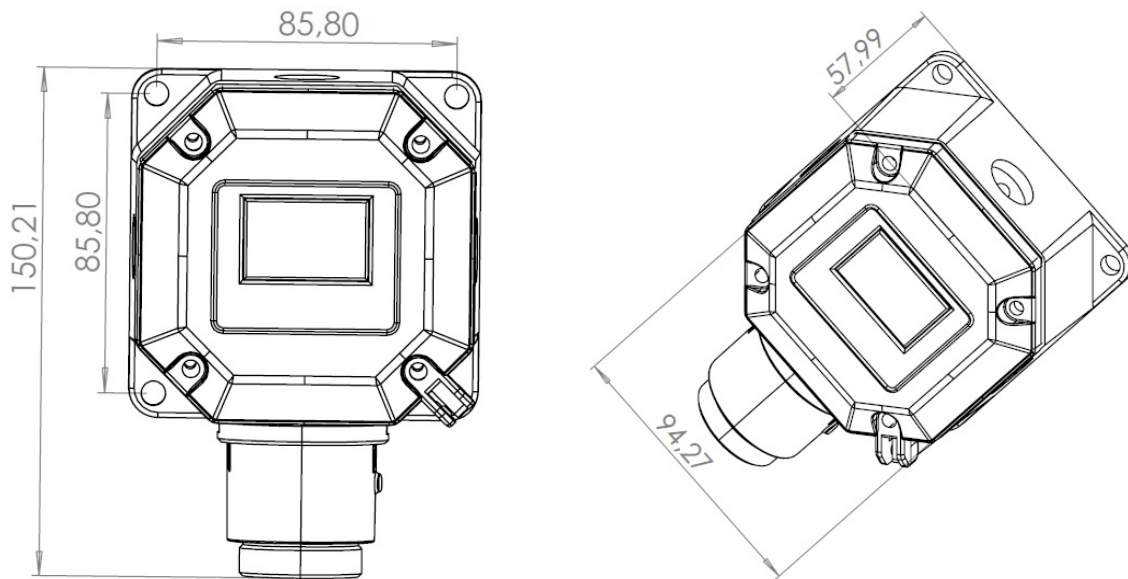

Diagram 2: Detector Body and Sensor Head Size

Sensor Head

The Prosense BTN series sensor head designed to detect flammable and toxic gases. Sensor head may include electrocatalytic technologies or a wide range of toxic gas sensors based on electrochemical cell (ECC) technology.

Installation

Gas detectors should be mounted where a potential hazard of gas is most likely to be present. The following points should be noted when locating gas sensors.

- When locating detectors consider the possible damage caused by natural events e.g. rain or flooding.
- Consider ease of access to the gas detector for functional testing and servicing.
- Consider how escaping gas may behave due to natural or forced air currents.

Note: The placement of gas detectors should be determined following the advice of experts having specialist knowledge of gas dispersion, experts having knowledge of the process plant system and equipment involved, safety and engineering personnel. The agreement reached on the location of detectors should be recorded.

Each gas has different nature depending on their density. The density of which is lower than air, such as hydrogen, methane or ammonia the sensor head must be located above a possible leak or at the highest points at which major concentrations of gas may be found. The gases and vapours with a density greater than air, the sensor head must be installed beneath a possible leak or at the lowest points at which such gases and vapours may be present. The density of which is higher than air the sensor head must be located where gas accumulate.

Mounting The Detector

The detector should be mounted vertically as the sensor head pointing downwards. Detector has to be mounted such that the sensor's gas entrance area.

The install location

- should be isolated from vibration, direct sun light and have temperature stability
- avoided external influences such as splashing water, oil, corrosive aerosols
- should have at least 30 cm free space beneath the sensor head to provide accessibility for calibration work.
- should be in air flow between possible leak or collection point and possible source of ignition.

Prosense do not recommend to install detectors to :

- directly above a cooking unit,
- directly above a sink unit,
- close to an extractor unit,
- outdoor without protection against the rain,
- in places where temperature is outside the admissible operating range,
- in corrosive environments,
- inside air vents.
- in environments where silicon can be found.

The Prosense detector has an integrated mounting screw holes on the body. The correct mounting position is given in Diagram 3:

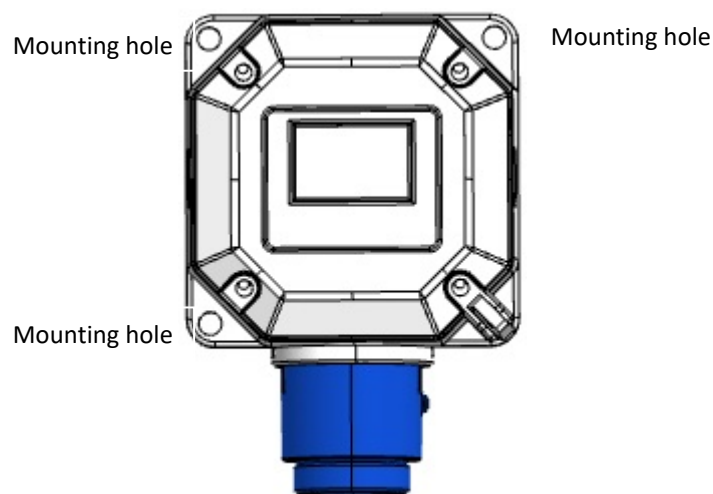

Diagram 3: Mounting holes on body

Cabling and Connections

Caution: All electrical connections should be made in accordance with any relevant local or national legislation, standards or codes of practice.

Prosense BTN series detectors can operate between 12 - 24 VDC. The connection socket located on main board. User should consider the cable length when performing installation in the field. The Prosense detector requires a power supply between 12VDC and 24VDC. Make sure that a minimum 12 VDC supply available at the detector entrance and consider the voltage drop due to cable resistance in case of long distance applications.

The use of industrial grade, suitably shielded field cable is recommended. The best practices shown that, screened 4 cores (plus screen 90% coverage), suitably mechanically protected copper cable with a suitable explosion-proof gland, or ¾" NPT steel conduit, depending on the distance between signal received or control panel and detector. It is recommended to use 1.5 mm² (16 AWG) cable.

V+, V-(GND) ports must be connected via using two-wire cable to supply 16VDC power to detector. If detector has RS485 communication module additional two wire cable should be used to connect A and B to read the output signal of detector from A and B ports. Connections should be made correctly with extra care to do not mix ports and not cause any damage on the detectors. Detector power connection should be done with 1.5mm² cross section cable. The total distance between control panel and detectors should not exceed 1km.

The wiring for detectors utilized with RS485 board should be done by using connection cable EIA RS485 2 core wires with section 0.22 / 0.35 mm² and shielded. Nominal capacity between the wires < 50pF/m and nominal impedance 120 Ohms.

In case RS485 communication module used on detectors to monitor through DP32 control panel, the V+, V- ports and A,B ports are located on different socket in both DP32 control panel and detector side. The connections should be done with care to do not mix power and RS485 ports. All detectors will be connected through one cable via hopping one detector to another till the last detector on the line.

There should be one master device and up to 32 slave devices in RS485 communication. The master is DP32 control panel and detectors will be the slave devices:

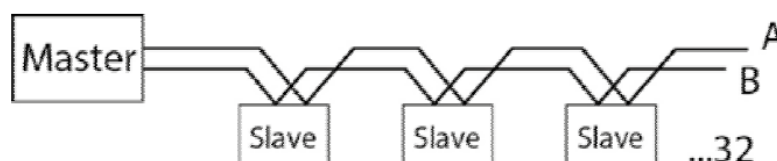

Diagram 4: RS485 communication

DP32 Panel

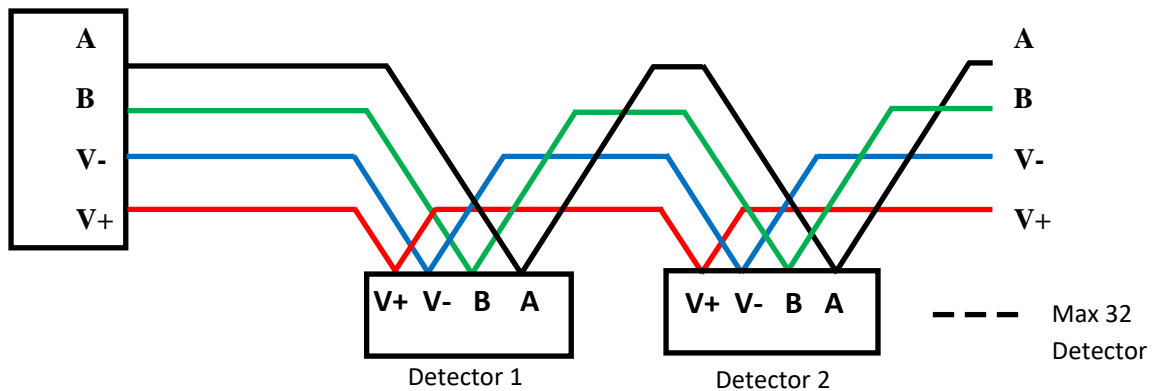

Diagram 5: Panel to detector connections

Each detector connected to DP32 panel should have unique address. Detectors having same address would not be recognised by control panel. DP32 panel can communicate up to 32 detectors. In case less than 32 detectors connected, control panel would not show non-existent detectors. Unused detectors should be deactivated on channel settings menu steps.

Important: The last detector at the communication line should have line termination resistor (120 Ohm) to enable communication for all detectors on the line. The resistor is not implemented on the board and user should connect it physically during the installation.

BTN Series Detectors Connections

BTN Series detectors has a power input and three relay output sockets on main board.

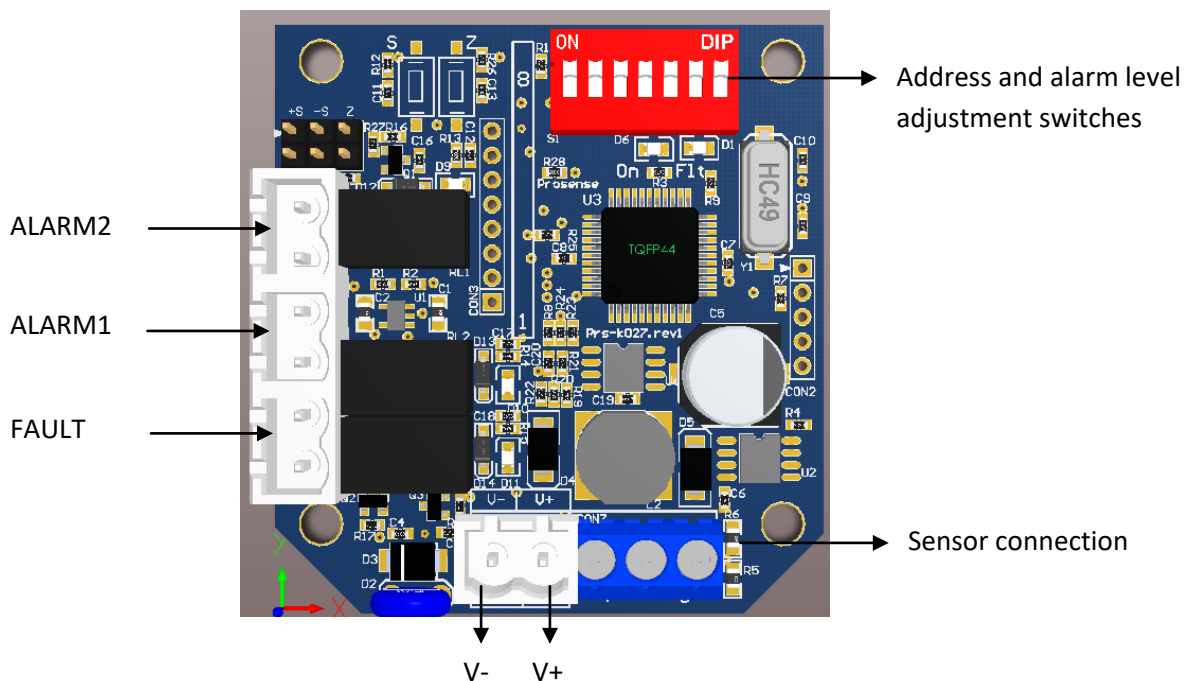

Diagram 6: BTN Series detector main board

Sensor connections are not used for external connections and should not be changed in any case. BTN Series detectors has three integrated relays on main board which are named as

Alarm1, Alarm2 and Fault. Relays are not energised and only works as NO (Normally Open) status. It is not possible to adjust relay activation method. Alarm1 relay will be activated when alarm1 threshold level exceeded. If measurement level increases Alarm2 relay activated together with Alarm 1. Fault relay will be activated only on fault conditions. Alarm levels are adjustable to predefined levels. Switches 6 and 7 should be used to change alarm levels.

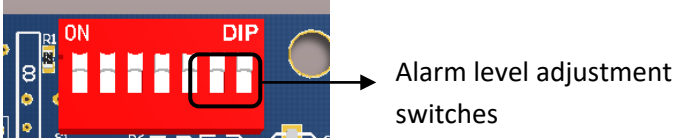

Diagram 7: BTN Series detector alarm level adjustment switches

Alarm levels and related switch positions are given in table-3:

Switch 6	Switch 7	Alarm1	Alarm2
OFF	OFF	10	15
OFF	ON	10	20
ON	OFF	30	40
ON	ON	40	60

Table 1: BTN Series detector alarm levels

Oxygen Detectors:

For oxygen detectors the output values and meanings are different as oxygen is naturally available in atmosphere. Alarm 1 is used to raise low level alarm and Alarm2 is used to raise high level alarm for Oxygen. Alarm levels are also different as given in below table: Alarm levels and related switch positions are given below:

Switch 6	Switch 7	Alarm1	Alarm2
OFF	OFF	18	23
ON	OFF	19	22
OFF	ON	18	22
ON	ON	19	23

Table 2: BTN Series Oxygen detector alarm level (% Volume) switch positions

BTN Series Detectors Connections with RS485 Module

When RS485 module installed on BTN series detectors the ALARM2 relay ports will be converted to RS485 ports automatically. The detector can still provide fault and alarm relays with RS485 communication module.

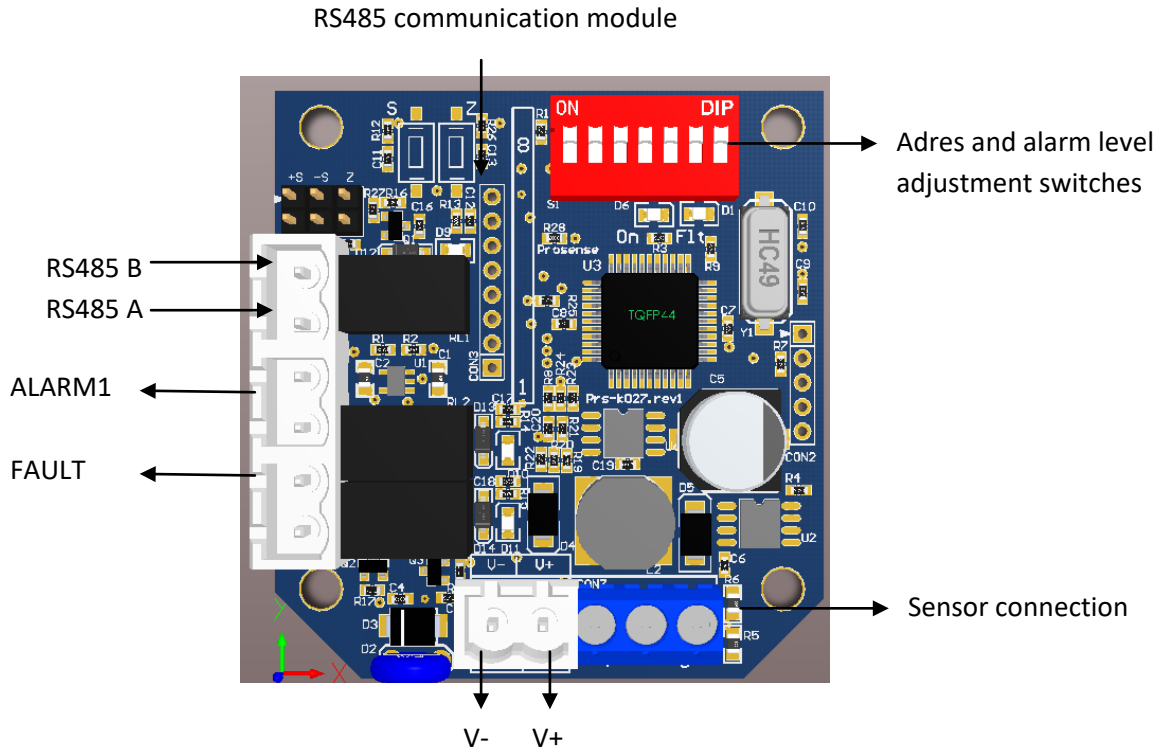

Diagram 8: BTN Series detector with RS485 module

Important: The last detector at the communication line should have line termination resistor (120 Ohm) to enable communication for all detectors on the line. The resistor is not implemented on the board and user should connect it physically during the installation between RS485A and RS485B ports.

BTN series detector main board has a dip-switch to assign address to the detector. Each detector must have unique address to communicate to DP32 Panel. Detectors having same address would not be recognised by the panel. The address should be set via using first 5 switches on the dip-switch.

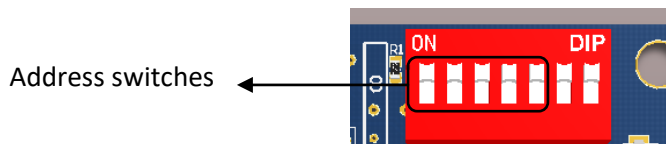

Diagram 9: BTN Series detector address switches

Detectors will be wired in daisy chain (bus) mode. We recommend not to use star mode connection due to negative impact of interference. Each detector should have unique address number in the chain. The detectors would not be recognised by control panel if same address

given to them. The address of detector can be adjusted via using DIP-Switch set on the board:

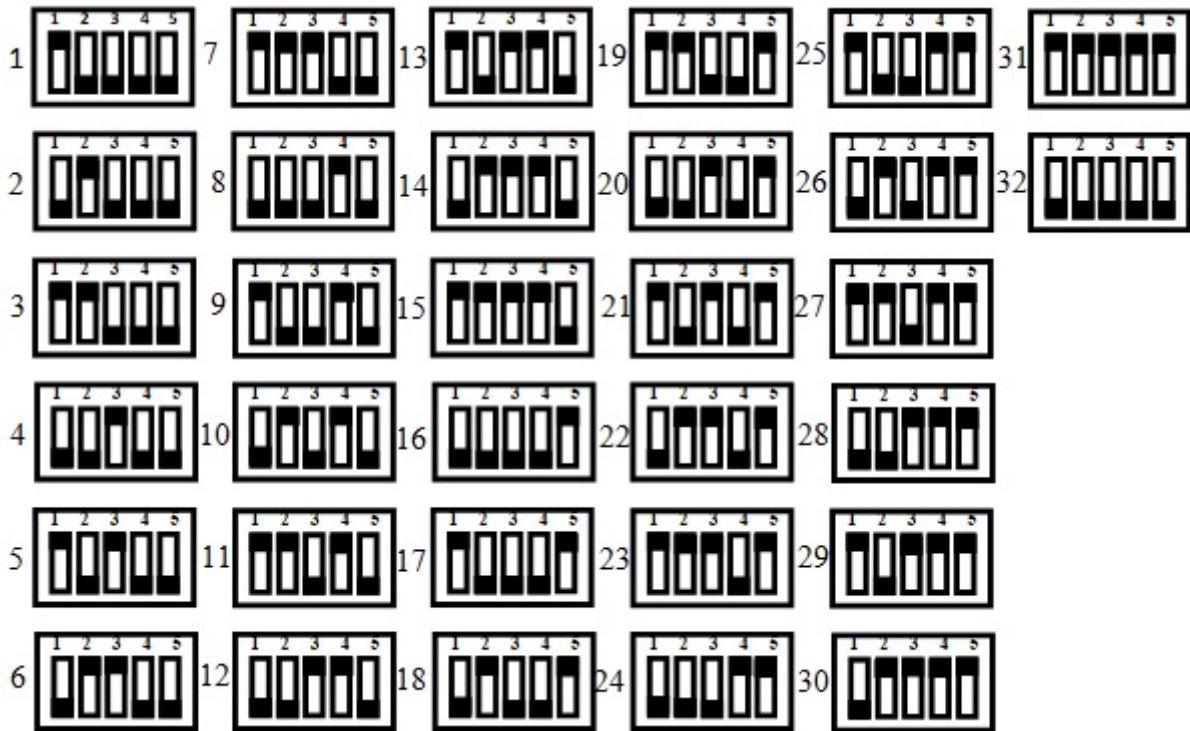

Diagram10: RS485 Modbus serial communication address and switch position

Important : Only the last detector on the serial bus should have end of line resistor.

System Status

Prosense BTN Series detectors has two LEDs on main board. Red LED shows system power status and yellow LED shows fault status. Both LEDs will start blinking right after power applied. After appoximitly 90 sec the yellow LED will be turned of and only red LED will continue blinking. This status means that detector is ready to normal operation.

First time switch on (Commissioning)

WARNING

The following procedure requires the detector cover to be removed while carrying out supply voltage checks. Therefore the appropriate permits to work should be sought in preparation. Prior to carrying out any HOT WORK ensure local and site procedures are followed. Ensure that the associated control panel output actuation is inhibited so as to prevent false alarms.

Caution: The following procedure should be followed carefully and only performed by suitably trained personnel

1. Remove the detector cover
2. Make sure the detector's output and power input connections done correctly
3. Check that all electrical connections are terminated correctly

4. Switch On the external power supply to feed the detector. If it is connected to DP32 Panel, cables should be installed according to DP32 Panel user manual as panel can provide both power and communication connections to the detectors.
5. Using a Digital Multi Meter (DMM), check the Supply Voltage at the terminals V+ and V- this should be a minimum supply voltage of 12VDC (Maximum supply voltage is 24VDC).
6. Check LED status on detector main board. LED status should be like explained above after applying power depending of the detector model.
7. Wait two minutes and confirm detector LED status pointing normal operation. If detectors used with DP32 Panel, panel should recognise each detector correctly at their addresses.
8. Switch Off the external power to the detector.
9. Fit the cover and make sure non of the cables cause an obstruction while fitting cover
10. Switch on external power to the detector or panel if used.

Calibration

It is recommended to periodically carry out calibration to ensure correct operation.

Calibration should be done by a person who trained and certified by local or international authorities.

Detector should be powered and stabilized for at least 30 minutes before calibration. For Flammable gas calibration use a calibration gas concentration of between 25%LEL and 75%LEL to ensure that the required accuracy can be attained. To calibrate the detector, use an appropriate span gas cylinder, constant flow regulator and Prosense Gas Cap. The flow rate used for calibration gas is 0.5 L/Min.

Important: Any optional board is installed on detector should be removed prior the calibration as some of the features masked or unavailable with them when installed.

Zero Calibration

It is recommended to use a compressed air cylinder (20.9%Vol oxygen) to perform the zero calibration if the area where the detector is located contains any residual amount of the target gas. If no residual gas is present then the background air can be used to perform the zero calibration. To perform Zero calibration put a jumper to Z pins on detector main board and press Zero button for 3 seconds. The zero level will be automatically adjusted.

Span Calibration

As there is only relay outputs and RS485 communication ports available on detector it is necessary to use a control panel to see gas measurement of the detector during the span calibration. If RS485 communication is not possible calibration should be done in a service center. To perform Span calibration apply gas to detector via using the Gas Cap while detector is energised and working. The signal level vary depending on the used gas for calibration and gas concentration. If the measured level is lower than the calibration gas level, put a jumper to S+ pin press to Span button till the level reaches the necessary value. If the measurement level is higher than the necessary value, put a jumper to S- pin and press

to Span button till the level reaches the necessarily value. Once the span calibration completed remove the jumper and put as a spare on to detector board.
 Important: Never put jumper on both S+ and S- pins and press any button.

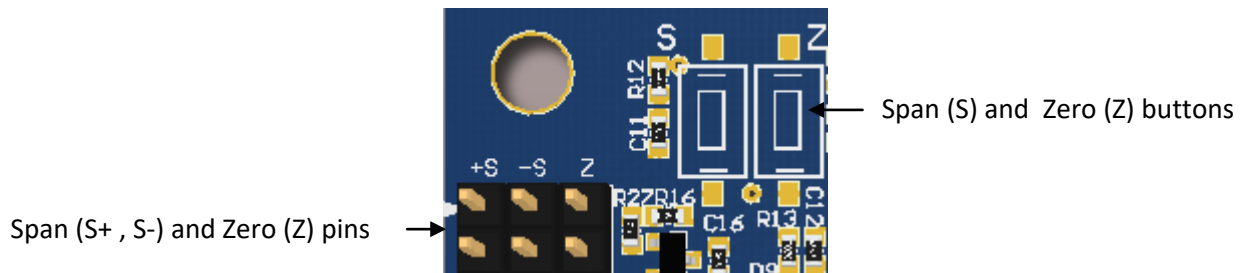

Diagram 11: Calibration buttons and pins

General Specification

BTN Series Detector Electrical Specifications:

Input Voltage Range	12 to 20VDC (16VDC nominal)
Max Power Consumption	0.96 Watts at 16VDC - normal condition 1.60 Watts at 16VDC - alarm and fault condition
Terminals	4 x 2 x screw terminals suitable for wire diameter 1.5mm ² to 2.5mm ²
Relays	3 x (1A 30VDC, 0.5A 125VAC, 0.3A 80VDC). Non-selectable: normally open and de-energized
Communication	RS485, Modbus RTU
Sensor	Catalytic

Table 2: BTN Series detectors electrical specifications

Detector Body Specifications:

Material	Plastic (black)
Weight	Plastic boat: 230g (with Sensor Header)
Mounting	Wall mounting
Entries	PG11

Table 3: Detector body specifications

Environmental:

IP Rating	IP54 (plastic boat)
Operating Temperature	-10°C to +50°C / 14°F to +120°F
Operating Humidity	Continuous 20-90%RH (non condensing)
Operating Pressure	90-110kPa
Storage Conditions	-10°C to +50°C (14°F to +120°F)

Table 4: Environmental specifications

Warranty Statement

All products are designed and manufactured to the latest internationally recognized standards by Prosense Technology under a Quality Management system that is certified to ISO 9001. As such Prosense Technology warrants its products against defective parts and workmanship and will repair or (at its option) replace any instruments which are or may become defective under proper use within 12 months from date of commissioning by an approved Prosense Technology representative or 18 months from date of shipment from Prosense Technology, whichever is the sooner. This warranty does not cover disposable batteries or damage caused by accident, abuse, abnormal operating conditions or poisoning of sensor.

Defective goods must be returned to Prosense Technology premises accompanied by a detailed description of any issue. Where return of goods is not practicable Prosense Technology reserves the right to charge for any site attendance where any fault is not found with the equipment. Prosense Technology shall not be liable for any loss or damage whatsoever or howsoever occasioned which may be a direct or indirect result of the use or operation of the Contract Goods by the Buyer or any Party.

This warranty covers instrument and parts sold to the Buyer only by authorized distributors, dealers and representatives as appointed by Prosense Technology. The warranties set out in this clause are not pro rata, i.e. the initial warranty period is not extended by virtue of any works carried out there under.

In no event will Prosense Technology be liable for any incidental damages, consequential damages, special damages, punitive damages, statutory damages, indirect damages, loss of profits, loss of revenues, or loss of use, even if informed of the possibility of such damages. Prosense Technology's liability for any claims arising out of or related to this product will in no case exceed the order value. To the extent permitted by applicable law, these limitations and exclusions will apply regardless of whether liability arises from breach of contract, warranty, tort (including but not limited to negligence), by operation of law, or otherwise.