



PROSENSE PE Series Gas Detectors Installation and User Manual



Prosense Teknoloji San. Ltd. Őti.
Cumhuriyet Mah. Mermer sok. No:16 Kartal İstanbul
Tel: (90) 216 306 77 88 Faks: (90)216 473 81 29

www.prosense.com.tr

WARNING!

This manual must be carefully read by all persons who have or will have the responsibility for installing, using or servicing this product.

Like any equipment, this product will perform as designed only if installed, used and serviced in accordance with the manufacturer's instructions. Otherwise, it could fail to perform as designed and persons who rely on this product for their safety could suffer severe personal injury or death.

The warranties made by Prosense with respect to this product are voided if the product is not installed, used and serviced in accordance with the instructions in this user guide. Please protect yourself and other by following them.

Important Remark

The detector has been factory-tested before delivery, the commissioning after installation must include the zero- and span-adjustment. The commissioning has to be terminated by a function test of the complete gas detection system.

CONTENTS

- Safety Information..... 4
 - Strictly follow the Instructions for Use..... 4
 - Maintenance..... 4
 - Use in areas subject to explosion hazards 4
 - Liability for proper function or damage 4
 - Intended Use 5
- Introduction..... 7
- Detector Body..... 8
- Sensor Head: 9
- Installation:..... 9
- Mounting the Detector: 9
- Electrical Connections 11
- Cabling..... 12
- Detector Grounding..... 13
- Default Configuration 14
- Detector Relay Module: **Hata! Yer işareti tanımlanmamış.**
- System Status 15
- First Time Switch On (Commissioning)..... 15
- Calibration 16
 - Zero Calibration 16
 - Span Calibration 16
- Maintenance 17
 - Proactive Maintenance: 17
 - Operational Life: 17
 - Servicing 17
 - Sensor Replacement:..... 17
 - Sinter Replacement: 17
 - Sensor Head Replacement: 18
 - Resetting the Detector: 18
- General Specification 19
- Safety instruction for hazardous area installation 20
- Declaration 22
- Warranty Statement..... 23

Safety Information

Ensure that this Operating Manual is read and understood **BEFORE** installing / operating / maintaining the equipment. Pay particular attention to Warnings and Cautions. All document Warnings are listed here and repeated where appropriate at the start of the relevant chapter(s) of this Operating Manual. Cautions appear in the sections/sub-sections of the document where they apply.

Strictly follow the Instructions for Use

Any use of the detectors requires full understanding and strict observation of these instructions. The detector is only to be used for purposes specified here.

The cover on Detector must be kept tightly closed until power to the detector is isolated otherwise ignition of a flammable atmosphere can occur. Before removing the cover for maintenance or calibration purposes, ensure the surrounding atmosphere is free of flammable gases or vapours.

Detectors must be protected from extreme vibration and direct sunlight in hot environments as this may cause the temperature of the detector to rise above its specified limits and cause premature failure.

Maintenance

It is recommended to obtain a service contract Prosense to carry out all repairs. Only authentic Prosense spare parts must be used, substitute components may invalidate the certification and warranty of the detector. Maintenance and calibration operations must only be performed by qualified service personnel.

Use in areas subject to explosion hazards

Equipment or components which are used in potentially explosive atmospheres and have been tested and approved according to international or European regulations may be used only under the conditions specified here. Modifications of components or the use of faulty or incomplete parts are not permitted. In case of repairs of equipment or components, the national regulations must be observed.

Liability for proper function or damage

The liability for the proper function of the detector is irrevocably transferred to the owner or operator to the extent that the detector is serviced or repaired by personnel not employed or authorized by Prosense or if the sensing head is used in a manner not conforming to its intended use. Prosense cannot be held responsible for damage caused by non-compliance with the recommendations given above. The warranty and liability provisions of the terms of sale and delivery of Prosense are likewise not modified by the recommendations given above.

Intended Use

The PE series detectors are intended to be used for stationary, continuous monitoring for combustible gas/air or vapour/air mixtures below the Lower Explosion Limit (LEL) and toxic gas/air mixtures in particule per million (PPM) units. The detectors are marked by the device categories II 2G that can be operated in hazardous areas with potentially explosive atmospheres of zones 1 and 2. The type of protection for gas explosion protection according to device category 2 (zones 1 or 2) is flameproof enclosure and increased safety, "db". The enclosure protection is IP 65.

According to the ATEX Directive 2014/34/EU and IECEx rules the detector is an assembly consisting of three components (Sensor Head, enclosure and cable gland), where all these three components are type approved according to ATEX and IECEx rules and marked by the device category II 2G. Thus this detector is suitable to be operated in hazardous areas with potentially explosive atmospheres of zone 1 and zone 2. The PE series detector comprises a gas sensor type Ex-proof (protection type flameproof enclosure db type). PE Series detector for flammable gases performs % 0 to % 100 LEL measurement range; for toxic gases the measurement range would be vary. The measurement range and environmental conditions are written on each detector label.

Hazardous area classifications:

Zone 0: An area classified as Zone 0 will have ignitable concentrations of flammable gases, vapours or liquids either continuously present or present for long periods of time under normal operating conditions

Zone 1: An area classified as Zone 1 is likely to have ignitable concentrations of flammable gases, vapours or liquids present under normal operating conditions. Flameproof (Ex db) detectors are suitable for use in Zone 1.

Zone 2: An area classified as Zone 2 is not likely to have ignitable concentrations of flammable gases, vapours or liquids present under normal operating conditions. Flameproof (Ex db) detectors are suitable for use in Zone 2.

Not to be used in oxygen enriched atmospheres.

P detectors for flammable gases with pellistor sensor are designed to detect gases or vapours in air and not inert or oxygen deficient atmospheres. P oxygen detectors can measure in oxygen deficient atmospheres.

In conjunction with the central controllers Prosense detectors with preadjusted alarm thresholds audible and visible alarm devices or automatic countermeasures can be activated before the detected gases or vapours can form dangerous flammable or toxic mixtures with air. Please be alerted in following special conditions may have impact on measuring function due to the nature of measuring method:

1. Very high gas concentrations

The measuring method of PE series detector based on heat produced by reaction on the oxidation of a flammable gas when pellistor sensor used. There is not enough oxygen in the sensor to perform oxidation process correctly in case of high gas concentrations. Hence the measuring signal decreases at high gas concentrations and even can lead to measuring signal within the measuring range again. In case of high flammable gas concentration, do not reset latching alarms without having ensured a safe condition in the environment via performing necessary checks.

2. Minimum oxygen concentration

The measuring principle of heat of reaction needs a minimum oxygen concentration of 15 % by volume; otherwise the measuring values will be too low because of oxygen deficiency.

3. Long-term gassing with methane at very low temperatures

If the Prosense PE series flammable gas detectors with pelistor sensor are operated applying with methane at very low temperatures, the measuring signal at long term exposition may decrease after alarm activation and may lead to misinterpretation.

If a gas alarm occurs, necessary actions need to be taken immediately. The decrease of the measuring signal does not mean that the gas concentration has been decreased. We recommend to keep alarms on the associated controllers and not to reset these alarms without performing measurement with an independent gas detector to make sure conditions are safe.

Introduction

The Prosense comprises a gas detector body and a sensor head for detecting flammable gases. The construction of Prosense allows it to be used in hazardous area locations; it may also be used in other areas not classified as hazardous.

Prosense detectors can be configured with a wide range of different sensors may be used to detect a broader range of target gases. The detector can be configured with optional relay board features two programmable relays for controlling external equipment e.g. alarms, sirens, valves or switches. The detector provides an industry standard 3-wire, 4-20mA output for connection to a dedicated gas detection control system or PLC.

Prosense detectors comprises of the main parts as shown below:

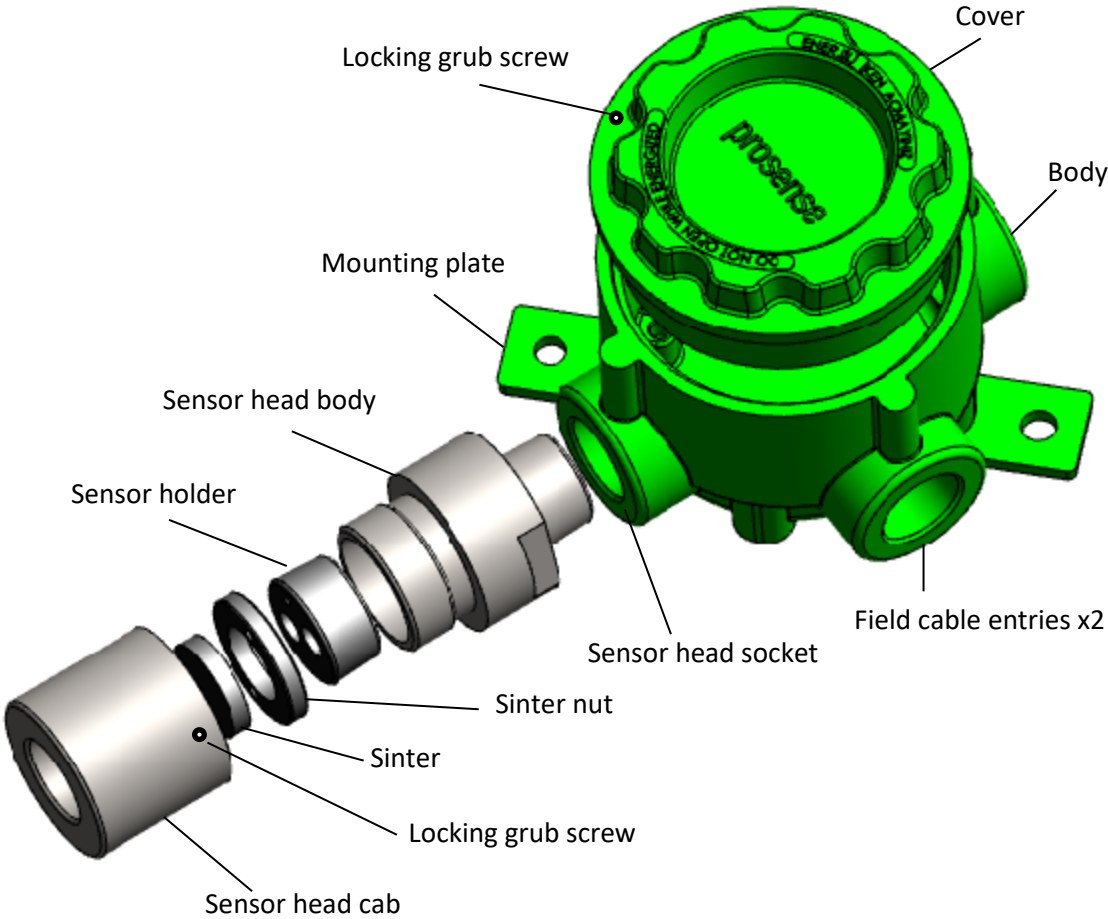

Diagram 1: Exploded view

Detector Body

The detector enclosure has three threaded entries. The two cable entries either side of the upper part of the transmitter housing are for connecting the power source, signal output and relay contacts to associated signalling equipment. The bottom entry allows direct connection of the sensor socket. There is a mounting plate incorporated into the transmitter housing allowing for various mounting configuration options.

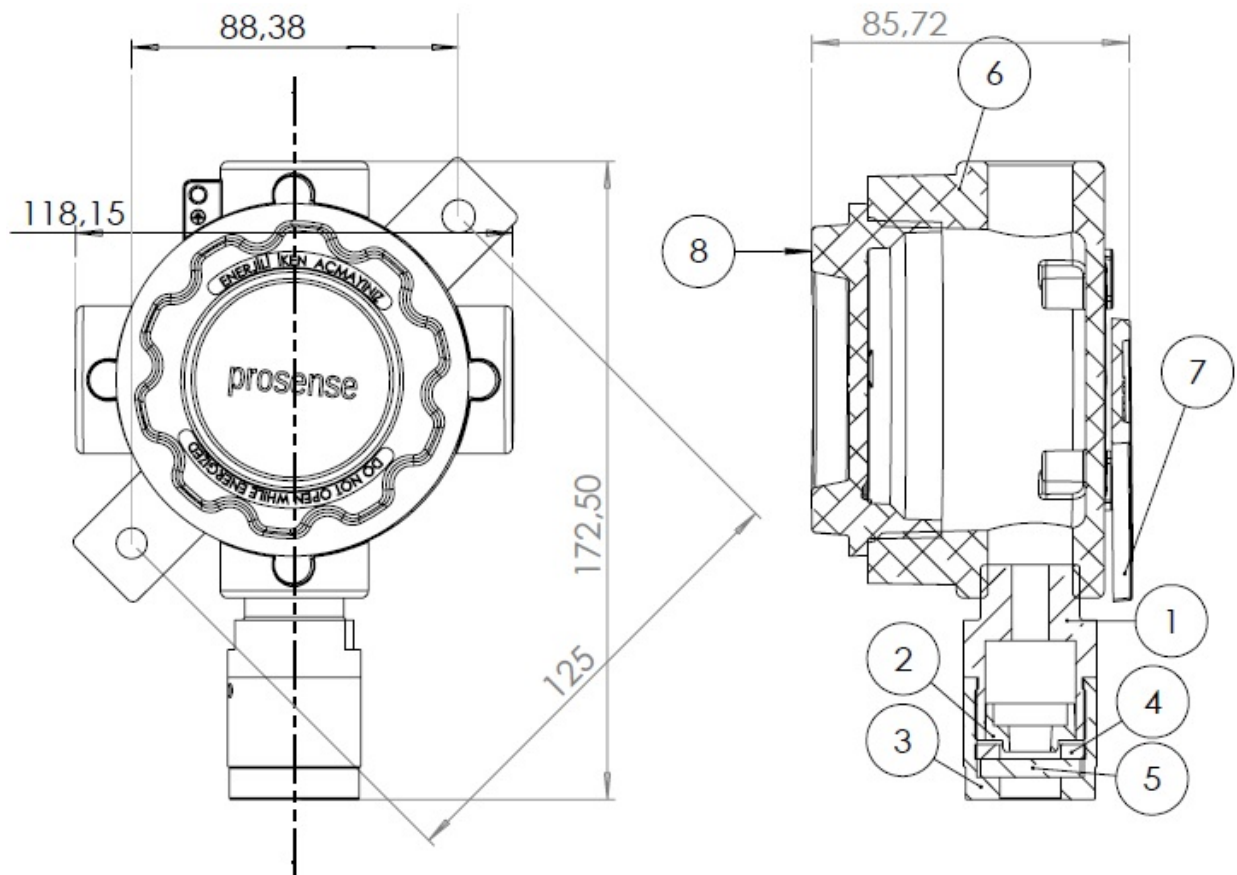

Diagram 2: Detector body size and Sensor Head components

- 1 : Sensor head body
- 2 : Sensor holder
- 3 : Sensor head cap
- 4 : Sinter nut
- 5 : Sinter
- 6 : Junction box – Detector body
- 7 : Wall mounting adapter
- 8 : Junction box cover

Sensor Head:

Prosense PE Series detectors equipped with catalytic sensors. Sensor head (SH10) components are explained in Diagram1.

Installation:

Gas detectors should be mounted where a potential hazard of gas is most likely to be present. The following points should be noted when locating gas sensors.

- When locating detectors consider the possible damage caused by natural events e.g. rain or flooding.
- Consider ease of access to the gas detector for functional testing and servicing.
- Consider how escaping gas may behave due to natural or forced air currents.

Note: The placement of gas detectors should be determined following the advice of experts having specialist knowledge of gas dispersion, experts having knowledge of the process plant system and equipment involved safety and engineering personnel. The agreement reached on the location of detectors should be recorded.

Each gas has different nature depending on their density. The density of which is lower than air, such as hydrogen, methane or ammonia the sensor head must be located above a possible leak or at the highest points at which major concentrations of gas may be found. The gases and vapours with a density greater than air, the sensor head must be installed beneath a possible leak or at the lowest points at which such gases and vapours may be present.

Mounting the Detector:

The detector should be mounted vertically as the sensor head pointing downwards. Detector has to be mounted such that the sensor's gas entrance area.

The install location

- should be isolated from vibration, direct sun light and have temperature stability
- avoided external influences such as splashing water, oil, corrosive aerosols
- should have at least 30 cm free space beneath the sensor head to provide accessibility for calibration work.
- should be in air flow between possible leak or collection point and possible source of ignition.

Prosense do not recommend installing detectors to:

- directly above a cooking unit,
- directly above a sink unit,
- close to an extractor unit,
- outdoor without protection against the rain,

- in places where temperature is outside the admissible operating range,
- in corrosive environments,
- inside air vents.
- in environments where silicon can be found.

The Prosense detector has an independent mounting plate consisting of two mounting holes and two holes to attach to detector body. The mounting plate can be adjustable on two diagonal ways on to detector body. The detector may be fixed directly to a surface mounting. Follow below steps to mount the detector:

- 1- Decide which diagonal way to use and adjust mounting plate on detector body if necessary.
- 2- Check and make sure mounting plate is completely fixed to detector body
- 3- Mount the detector to the surface via using two outer mounting holes on mounting plate.

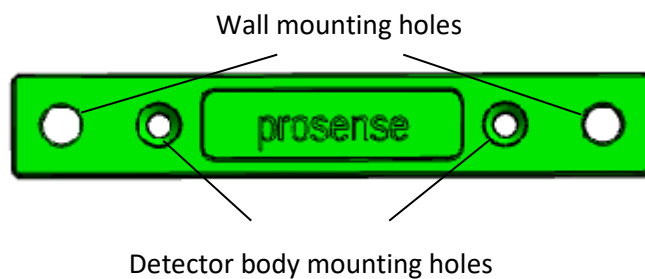

Diagram 3: Detector mounting plate

The mounting plate installed in below position at factory:

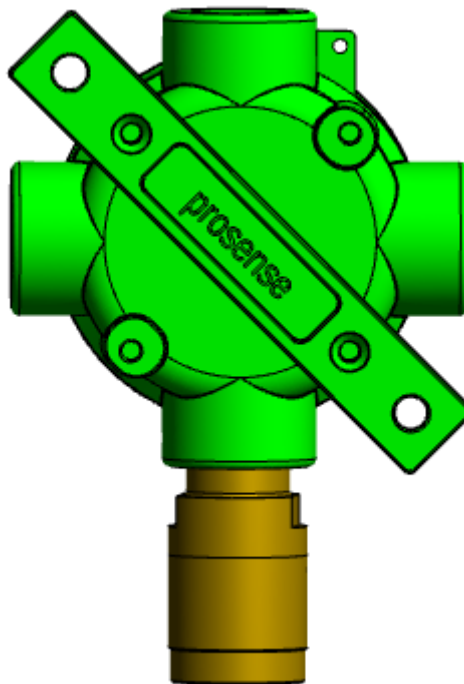

Diagram 4: Default installation of mounting plate

Electrical Connections

Caution: All electrical connections should be made in accordance with any relevant local or national legislation, standards or codes of practice.

Prosense detectors can operate between 12 - 24 VDC. The connection socket located on main board as given in Diagram 8 and details given in below Table 2:

Output	Usage
V +	Power input (+) 12VDC – 24VDC
V -	Power input (-) 12VDC – 24VDC
S	Current Output Signal (4mA – 20mA)

Table 1 : Detector output ports and their usage

The detector designed to give 4 - 20 mA current output signal. It is also possible to get voltage value via using an additional resistor. Below Table 3 gives recommended resistor specifications to get correct voltage output from detector depending of the power source level:

Detector Power VDC	Resistor	Signal level (4mA – 20mA)
12 VDC – 24 VDC	250 Ω, tolerance %1	1 VDC – 5 VDC
12 VDC – 24 VDC	500 Ω, tolerance %1	2 VDC – 10 VDC

Table 2 : Detector power and the output resistor

Please consider the cable length when performing installation in the field. The Prosense detector requires a power supply between 12VDC and 24VDC. Make sure that a minimum 12 VDC supply available at the detector entrance and consider the voltage drop due to cable resistance in case of long-distance applications. The maximum loop resistance in the field cable is calculated as follows:

$$R \text{ loop} = (V \text{ controller} - V \text{ detector min}) / I \text{ detector}$$

Example;

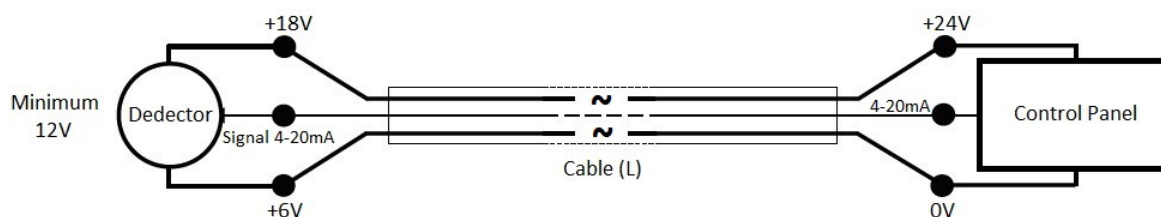

Diagram 5: Field cabling

The controller or power supply is supplying a nominal 24VDC (V controller), the detector minimum allowable voltage is 12VDC (V detector min), therefore the maximum allowable voltage drop between the controller and detector is 12VDC; this means a voltage drop of 6V in each core (V+ core and V- core). Maximum power consumption of the detector when

optional relay modules installed and all relays are active is 2.5W. The current required to drive the detector at the minimum voltage is $(I = P / V): 2.5 / 12 = 210\text{mA}$ (I detector).

So, the maximum field cable loop resistance ($R_{\text{loop}} = 12 / 0.21 = 56 \text{ Ohms}$, or 28 Ohms per core, (allowing for component variations, losses, etc.). The following tables show the maximum cable distances between the controller and transmitter assuming a voltage drop of 6V in each core and for different cable parameters. The tables are examples only and actual cable parameters and source power supply voltage for the application should be used to calculate the maximum cable distance allowed at the installation site.

Typical cable details:

Cable size (cross sectional area)	Cable type nearest equivalent	Cable resistance Ω/km	Maximum Cable length (L) Meters
0.5mm ²	20AWG	36.8 Ω/km	~500
1.0mm ²	17AWG	19.5 Ω/km	~800
1.5mm ²	16AWG	12.7 Ω/km	~1200
2.0mm ²	14AWG	10.1 Ω/km	~1500
2.5mm ²	13AWG	8.0 Ω/km	~1800

Table 3 : Typical cable details and maximum distance for cabling

Cabling

The use of industrial grade, suitably shielded field cable is recommended. The best practices shown that, screened 3 cores (plus screen 90% coverage), suitably mechanically protected copper cable with a suitable explosion-proof gland, or 3/4" NPT steel conduit, depending on the distance between signal received or control panel and detector 0.5 to 2.5 mm² (20 to 13 AWG) conductors can give better results. Ensure the cable gland is installed correctly and fully tightened.

Cable and Earth/Ground regimes

Effective Earth/Ground bonding is important to ensure good EMC and RFI immunity. The following diagrams show examples of how to earth/ground bond the cable at enclosures. The same principles apply to conduit installations. These bonding techniques provide good RFI/EMC performance. Earth/ground loops must be avoided to prevent the risk of false signal variation.

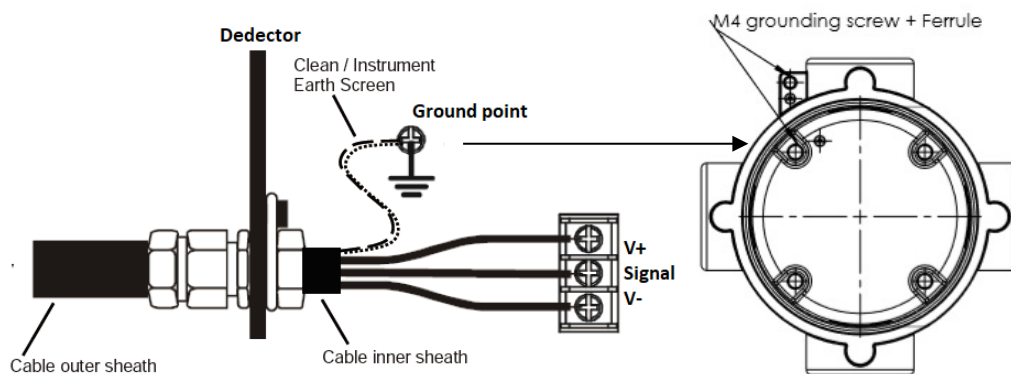

Diagram 6: Grounding

The Earth Screen of the field cable should be “tied to Earth” or connected to Ground at one point only. It is common practise to adopt a STAR EARTH connection regime where all instrumentation Screens are connected at one common point. The Screen at the other end of the cable should be “parked” or terminated into a blank terminal.

Detector Grounding

Internal Ground connection: Each detector has grounding screw which utilizes grounding for detector main PCB to detector body. The screw should be located correctly and fixed for all times. In case of any maintenance activity this screw should be checked and fixed to make sure for proper grounding.

External Ground Connection: It is recommended to utilize a No 14 AWG copper, (Stranded or Solid), wire. Loosen the screw sufficiently to enable ‘wrapping the wire around the screw in a “U” shape. Raise the clamp and place the wire between the clamp and ground base, lower the clamp and tighten the screw to 10.4lb-in torque.

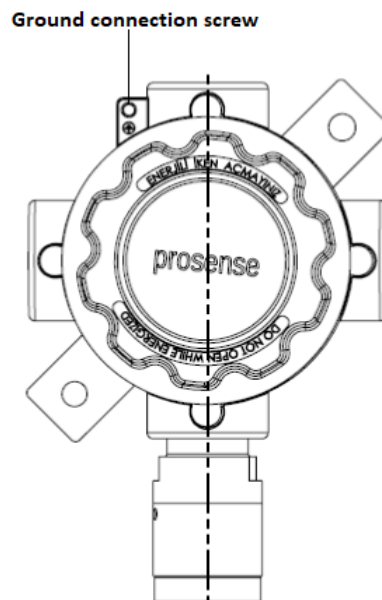

Diagram 7: Detector grounding screw

The following diagrams show how to install the wire into the ground screw of the enclosure.

1. Loosen grounding screw
2. Insert grounding cable
3. Fasten grounding screw

Default Configuration

Prosense detectors preconfigured to provide signal from analogue output depending on the detector and gas type:

Function	Value/Setting	Meaning
Signal output	2.0 mA	Fault
	3.0 mA	Warm-up
	4.0 mA to 20.0 mA	Normal gas measurement
	21.0 mA	Maximum over range

Table 4 : Detector default configuration details

Detector Main board and connection details given in Diagram 8:

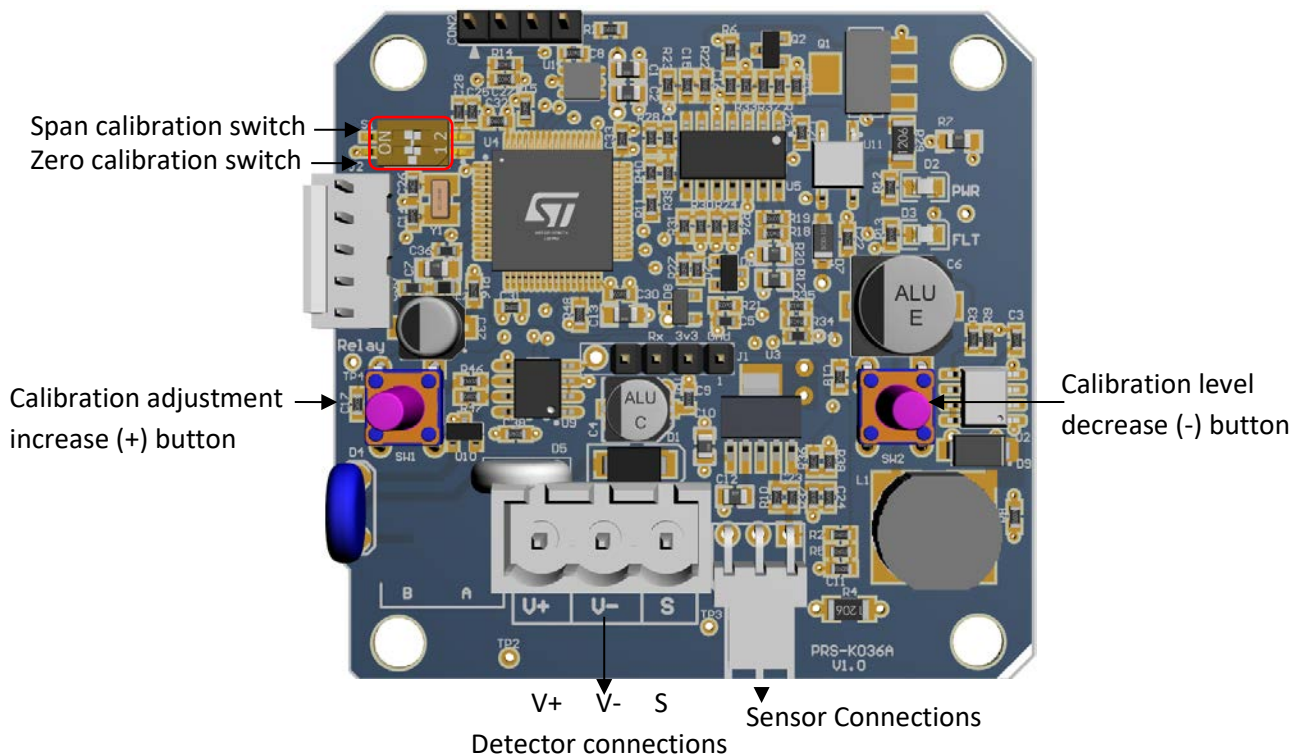

Diagram 8: Detector main board and connections

Sensor connections are input to detector main board and already connected to sensor inside the sensor head. Only detector connections (S, V-, V+) should be used to connect outside:

Port	Usage
V +	Power input (+) 12VDC – 24VDC
V -	Power input (-) 12VDC – 24VDC
S	Current Output Signal (4mA – 20mA)

Table 5 : Detector output ports and their usage

The default configuration provides single 4-20mA signal output. Prosense detectors can be connected to control panels on the market having 4-20mA input signal. Signal wiring from detector and the control panel should be carried out by shielded cables. Wires cross section depends on the distance between the control panel and the detector. The details given in power

cabling are valid as well for signal output. We recommend using values given in table 4 as cabling best practices.

Please avoid any interruption in case any junctions on wires. The shield is to be grounded from the control panel side only and never connect the shield to the detector. Please make sure clutching or crimping apparatus are not loosen or oxidized.

System Status

The Prosense PE series detectors have two LEDs on main board. Red LED shows system power status and yellow LED shows fault status. Both LEDs will be illuminated right after applying power. After approximately 90 sec the yellow LED will be turned off and only red LED will continue blinking. This status means that detector is ready to normal operation. There will be 2mA signal output during warm-up time. Following warm-up time the signal current will be 4mA. Here is the LED status table:

LED	Warm-up	Normal Operation	Fault	Calibration*
Power / Red	Blinking	Blinking	Blinking	Blinking
Fault / Yellow	Blinking	Solid Off	Solid On	Solid On

Table 9: LED status and meanings

*calibration operation would progress a short while not more than 30 seconds

First Time Switch On (Commissioning)

WARNING: The following procedure should be followed carefully and only performed by suitably trained personnel

The following procedure requires the detector Cover to be removed while carrying out supply voltage checks. Therefore, the appropriate permits to work should be sought in preparation. Prior to carrying out any HOT WORK ensure local and site procedures are followed. Ensure that the associated control panel output actuation is inhibited so as to prevent false alarms.

1. Remove the detector cover
2. Configure the detector's analogue output signal and power input connections correctly
3. Check that all electrical connections are terminated correctly
4. Switch On the external power supply to feed the detector
5. Using a Digital Multi Meter (DMM), check the Supply Voltage at the terminals V+ (24V) and V- (0V), this should be a minimum supply voltage of 12VDC (Maximum supply voltage is 24VDC)
6. Check LED status on detector main board. Both LEDs will be illuminated right after applying power.
7. Wait two minutes and confirm that the yellow LED turned off and only red LED blinking.
8. Switch Off the external power to the detector.
9. Fit the cover and make sure none of the cables cause an obstruction while fitting cover
10. Switch on external power to the detector.

Calibration

It is recommended to periodically carry out calibration to ensure correct operation. Calibration should be done by a person who trained and certified by local or international authorities. Detector should be powered and stabilized for at least 30 minutes before calibration. During the calibration phases the detector output is inhibited (default 2mA) to avoid false alarms. For Flammable gas calibration use a calibration gas concentration of between 25%LEL and 75%LEL to ensure that the required accuracy can be attained. To calibrate the detector, use an appropriate span gas cylinder, constant flow regulator and Prosense Gas Cap. The flow rates used for calibration gas should be 0.5 L/Min.

It is recommended to use a compressed air cylinder (20.9%Vol oxygen) to perform the zero calibration if the area where the detector is located contains any residual amount of the target gas. If no residual gas is present then the background air can be used to perform the zero calibration.

Important: Any optional board is installed on detector should be removed prior the calibration as some of the features masked or unavailable with them when installed.

To calibrate the detector, follow the procedure below.

Zero Calibration

The detector signal output should be 4 mA when there is no target gas exist on the area or a clean compressed air applied to detector. Use a multimeter to check signal output. If the signal output is different than 4 mA, enable the zero calibration switches SW1 ON and SW2 OFF position. Calibration switches are shown on Diagram 8. The analogue output current should be monitored by a digital multimeter. Clean air or zero calibration gas must be applied to sensor for a minute by calibration adapter and gas regulator. User must start calibration via pressing both buttons on detector PCB at same time and 10 seconds continuously. Detector will adjust analogue current signals to 4mA after 60 seconds and complete zero calibration. Please adjust switch positions to default status after completing the calibration.

The fault LED (yellow) will be lit during the zero calibration and should go off when calibration completed.

Span Calibration

To perform Span calibration, the calibration switches shown in Diagram-8 should be set to SW1 OFF and SW2 ON position. The current level of detector output should be continuously monitored using a measuring instrumentsuch as Digital Multimeter (DMM). The calibration head should be attached to the sensor head and the calibration gas should be applied to the sensor at a constant flow rate of 0.5L/min using the regulator. Depending on the concentration level of the gas used for calibration, the analogue output current level will be different. The gas should be applied for about one minute while output current level monitored on DMM. Calibrator should continue exposing gas till the current level will be stabilised. Enable span calibration mode via pressing both buttons on the detector simultaneously for 10 seconds. The detector automatically sets the analog current signal level to 12mA and span calibration will be completed in 60 seconds. In this case, the detector will record the gas

applied to it as 50%LEL. If the gas applied to the detector is at a different level, the analog current signal must be adjusted according to the used gas type and concentration. In this case, if the measured value is higher than the reference value, the calibration level decrease (-) button should be pressed until the current level is brought to the reference value. If the measured value is lower than the reference value, the calibration level increase (+) button should be pressed until the current level is brought to the reference value. The fault LED (yellow) will be lit during the span calibration and should go off when calibration completed. When the span calibration is complete, the gas should be cut off, the gas cap removed, and the calibration keys returned to their initial state.

Maintenance

Proactive Maintenance:

All gas detectors including both for flammable and toxic gases should have to pass a functional test and calibration every three to six months according to EN 60079-17 industrial standards. The test results and calibration reports should be recorded in maintenance books.

Operational Life:

Catalytic flammable gas sensor suffers from a loss of sensitivity when in the presence of poisons or inhibitors, e.g. silicones, sulphides, chlorine, lead or halogenated hydrocarbons. The pellistors are poison resistant to maximize the operational life of the Catalytic flammable sensor. A typical operating life, subject to the presence of poisons/inhibitors is 36 months.

Servicing

Important: All replacement actions (sensor, sinter, and sensor head) shall be done by Prosense service personnel as it needs some special steps that should be performed in laboratory environment.

Sensor Replacement:

The Flammable Catalytic cells that are used with the Prosense Sensor Head have no serviceable parts. When they have reached the end of their operational life, simply replace the cell.

Sinter Replacement:

Due to environmental conditions the metal filter - sinter at sensor head might lost permeability that could negative impact on sensor performance. For example, if the installation includes cement or similar dust the sinter would be block the air/gas entry to sensor. The sinter should be checked visually and replaced if necessary. To replace sinter please check Diagram-1 and follow the below procedure:

- 1- Power of the Prosense detector
- 2- Loosen the locking grub screw
- 3- Unscrew the sensor head cap that holds the dirty sinter
- 4- Screw the sensor head cap including the clean sinter
- 5- Fix the Locking grub screw

Sensor Head Replacement:

Prosense sensor head is a separate part that can be replaced in the field. The sensor head includes integrated sensor, electronic device and sinter in it. To replace sensor head:

- 1- Power-Off the Prosense detector
- 2- Disconnect sensor cables from the detector main board
- 3- Remove the sensor head from the body
- 4- Install sensor head
- 5- Connect the sensor cables to detector main board
- 6- Power-On Prosense detector
- 7- Leave detector working at least 4 hours in clean air environment
- 8- Reset the detector via following steps given in “Resetting the detector” section

It is highly recommended to perform detector calibration after sensor head replacement. If this is not possible, please check and adjust span signal level.

Resetting the Detector:

It may be necessary to reset the detector when it has been reinstalled to different location or following the sensor head replacement.

To reset Prosense detector:

- 1- Make sure there is no gas exist that may affect on sensor. It is recommended to use clean air cylinder during reset.
- 2- Put ON position both Zero and Span switches on Calibration dip-switch
- 3- Press Calibration increase (+) and calibration decrease (-) buttons at same time
- 4- The power LED will stop blinking and fault LED will start blinking in fast mode. When LED status confirmed release the buttons.
- 5- Put ON position both Zero and Span switches on Calibration dip-switch and wait for at least 2 minutes to detector return back to normal operation.

Important: It is important to perform calibration following the reset operation to make sure detector working correctly on given range. If calibration is not done following the reset operation the detector will not work correctly.

General Specification

Use:

3-wire, 4-20mA, gas detector transmitter for use with directly installed flammable gas sensors. For the protection of personnel and plant from flammable gas hazards.

Electrical Specifications:

Input Voltage Range	12 to 24VDC (24VDC nominal)
Max Power Consumption	Max 2.5 Watts. at 24VDC
Current output	4-20mA
2.0 mA	Fault
4.0 mA to 20.0 mA	Normal gas measurement
2.0 mA to 2.5 mA	Inhibit (during configuration/warming)
21.0 mA	Maximum over range
Terminals	3 x screw terminals suitable for wire diameter 0.5mm ² to 2.5mm ² (20AWG to 13AWG).
Relays (optional)	2 x (1A 30VDC, 0.5A 125VAC, 0.3A 80VDC). Selectable normally open or normally closed (switch). Alarm relays de-energised.

Table 10: Electrical specifications

Detector Body Specifications:

Material	Epoxy painted aluminium alloy
Weight	Aluminium Alloy :1.33kg (with Sensor Header SH10)
Mounting	Wall mounting
Entries	½ NPT and ¾ NPT (or 2 x ¾ NPT) field cable entries, ¾ NPT sensor entry

Table 11: Detector body specifications

Environmental:

IP Rating	IP65 in accordance with EN60529:1992
Operating Temperature	-40°C to +70°C / -40°F to +158°F
Operating Humidity	Continuous 20-90%RH (non condensing) Intermittent 10-99%RH (non condensing)
Operating Pressure	90-110kPa
Storage Conditions	-30°C to +70°C (-22°F to +158°F)

Table 12: Environmental specifications

Safety instruction for hazardous area installation

Prosense P and PE series gas detectors are projected and built according to ATEX Directive 2014/34/EU and IECEx standards with reference to standard EN 60079-0, EN 60079-1. "ATEX", by the French "ATmosphere EXplosible", provides the technical requirements to be applied to equipment intended for use in potentially explosive atmospheres. The Prosense P, PE, PEK and PES Series series gas detectors must be installed and maintenance according to the suitable standards for electrical application in potentially explosive atmospheres (example: EN 60079-14, EN 60079-17 or other national standards).

Read this instruction first and keep this instruction manual always available.

The following instructions apply to equipment covered by ATEX and IECEx certificate number:

1. Prosense P and PE series gas detectors may be installed in hazardous area with flammable gases, vapors, and mist, group II, category 2G, maximum superficial permissible temperature 70°C.

Device category 2G, Identification II 2G

Ex db IIC T4 Gb (Tamb = -40÷+70 °C or -40÷+50 °C)

Ex db IIC T5 Gb (Tamb = -40÷+40 °C)

It means:  (European Community logo for ATEX applications) – group II (potentially explosive atmospheres – surface application – OTHER than mines)

Category 2G (G => Gas) – Zone 1 and Zone 21

Ex db => protection mode: explosion proof enclosure

IIC => define kind of gases

T4 Gb (Tamb = -40÷+70 °C or -40÷+50 °C)

T5 Gb (Tamb = -40÷+40 °C) => Temperature class -- Maximum allowable surface temperature.

IP 65 => Mechanical protection degree – protection against solid, dust and liquid.

2. Suitably trained personnel shall carry out installation in accordance with applicable code practice.

3. The electrical devices must be grounded using their grounding connections. The grounding connection must be ATEX/IECEx certified, suitable for the application required, substances, maximum superficial temperature, ambient temperature.

4. The user should guarantee periodical cleaning of the places where dust can storage to avoid the paling up to 5 mm.

5. The user should not repair this equipment.

6. The user should guarantee the keeping of the safety characteristic of the device after maintenance of repairing.

7. If the equipment is likely to come into contact with aggressive substances, it is responsibility of the user to take suitable precautions that prevent it from being adversely affected, thus ensuring that the type of protection is not compromised.

Aggressive substances: example Acids, liquid, gases with can affected metals

8. To guarantee the respect of the protection degree cable glands, blanking elements and thread adapters shall be certified Ex components according to protection "d" and a blanking element shall not be used with an adapter.

9. Sinter replacement shall be done by an approved technical service personal according to PE series and PE series user manual "Sinter replacement" procedure (PRS-UM-P-EN and PRS-UM-PE-EN).

10. Oring is made of Silicone and continuous operating temperature is -50C to 105C

11. If temperature exceeds 70°C at entry or 80°C at branching point use suitably rated cable and cable glands or conductors in conduit.

12. Thickness of outer painting is between 40 μm – 80 μm .
13. Maximum power consumption of the detector with optional boards installed is $P_{\text{max}}=2.5\text{W}$ where $I_{\text{max}}=100\text{mA}$ and $V_{\text{max}}=24\text{VDC}$.
14. All electrical connections should be made in accordance with any relevant local or national legislation, standards or codes of practice. Prosense detectors can operate between 12 - 24 VDC.
15. The use of industrial grade, suitably shielded field cable is recommended. The best practices shown that, screened 3 cores (plus screen 90% coverage), suitably mechanically protected copper cable with a suitable explosion-proof gland, or $\frac{3}{4}$ " NPT steel conduit, depending on the distance between signal received or control panel and detector 0.5 to 2.5 mm^2 (20 to 13 AWG) conductors can give better results. Ensure the cable gland is installed correctly and fully tightened.
16. Effective Earth/Ground bonding is important to ensure good EMC and RFI immunity. The Earth Screen of the field cable should be "tied to Earth" or connected to Ground at one point only. It is common practise to adopt a STAR EARTH connection regime where all instrumentation Screens are connected at one common point. The Screen at the other end of the cable should be "parked" or terminated into a blank terminal.
17. Each detector has grounding screw which utilizes grounding for detector main PCB to detector body. The screw should be located correctly and fixed for all times. In case of any maintenance activity this screw should be checked and fixed to make sure for proper grounding. It is recommended to utilize a No 14 AWG copper, (Stranded or Solid), wire.

Declaration



EU Declaration of Conformity

Prosense Teknoloji San Ltd. Şti declares the P, PE, PEK and PES Series products to be in accordance with the following standards and directives.

Name and address of Manufacturer: **Prosense Teknoloji San Ltd Şti**
Cumhuriyet Mah. Mermer Sok No:16
34876 - Kartal – İstanbul – Türkiye

Description of Devices: P, PE, PEK and PES Series Fixed Type Gas Detectors

Ex Designation:  **II 2G Ex db IIC T5 Gb**

Applied Harmonized international standards:
EN/IEC 60079-0:2018 Equipment – General requirements
EN/IEC 60079-1:2014 Equipment protection by flameproof enclosures 'd'
EN/IEC 50270:2015 Electromagnetic compatibility - Electrical apparatus for the detection and measurement of combustible gases, toxic gases and oxygen

Applied European Directives:
2014/34/EU ATEX Directive
2014/30/EU Electromagnetic Compatibility (EMC) Directive

Each P, PE, PEK and PES Series gas detector device which the Production Quality Assurance procedures and Type Examination procedures have been applied has been shown to conform to an approved Type and to the applicable classification rules and essential principles before being supplied. This declaration is being made on the basis of the following certificates:

Quality Management Certificate: **18ISO0073**
Production Quality Assurance Certificate: **ExVeritas 18PQAN0072**
Type Examination Certificate: **IMQ19 ATEX 045 X**
IT/IMQ/ExTR18.0009/02

Authorised Signatory: **Firat Celep**
Production Manager

Date: 12.10.2022

Warranty Statement

All products are designed and manufactured to the latest internationally recognized standards by Prosense Technology under a Quality Management system that is certified to ISO 9001. As such Prosense Technology warrants its products against defective parts and workmanship and will repair or (at its option) replace any instruments which are or may become defective under proper use within 12 months from date of commissioning by an approved Prosense Technology representative or 18 months from date of shipment from Prosense Technology, whichever is the sooner. This warranty does not cover disposable batteries or damage caused by accident, abuse, abnormal operating conditions or poisoning of sensor.

Defective goods must be returned to Prosense Technology premises accompanied by a detailed description of any issue. Where return of goods is not practicable Prosense Technology reserves the right to charge for any site attendance where any fault is not found with the equipment. Prosense Technology shall not be liable for any loss or damage whatsoever or howsoever occasioned which may be a direct or indirect result of the use or operation of the Contract Goods by the Buyer or any Party.

This warranty covers instrument and parts sold to the Buyer only by authorized distributors, dealers and representatives as appointed by Prosense Technology. The warranties set out in this clause are not pro rata, i.e. the initial warranty period is not extended by virtue of any works carried out there under.

In no event will Prosense Technology be liable for any incidental damages, consequential damages, special damages, punitive damages, statutory damages, indirect damages, loss of profits, loss of revenues, or loss of use, even if informed of the possibility of such damages. Prosense Technology's liability for any claims arising out of or related to this product will in no case exceed the order value. To the extent permitted by applicable law, these limitations and exclusions will apply regardless of whether liability arises from breach of contract, warranty, tort (including but not limited to negligence), by operation of law, or otherwise.