



PROSENSE DP32 Gas Control Panel User Manual



Prosense Teknoloji San. Ltd. Şti.
Cumhuriyet Mah. Mermer sok. No:16 34876 Kartal/İstanbul
Tel: (90) 216 306 77 88 Faks: (90)216 473 81 29
www.prosense.com.tr

WARNING!
READ THIS INSTRUCTION FIRST!

This manual must be carefully read by all persons who have or will have the responsibility for installing, using or servicing this product.

Like any equipment, this product will perform as designed only if installed, used and serviced in accordance with the manufacturer's instructions. Otherwise, it could fail to perform as designed and persons who rely on this product for their safety could suffer severe personal injury or death.

The warranties made by Prosense with respect to this product are voided if the product is not installed, used and serviced in accordance with the instructions in this user guide. Please protect yourself and other by following them.

WARNING!

Inductive or capacitive loads like motors, ventilation, e.g. should not be directly connected to the panel directly. In such cases, auxiliary external relays should be use to drive these loads.

Contents

- 1. INTRODUCTION 4
 - 1.1 Technical Specifications 4
 - 1.2 Panel Dimensions 5
- 2. INSTALLATION 5
- 3. FUNCTIONS and DETAILS 7
 - 3.1 LCD Screen: 9
- 4. MAIN BOARD AND CONNECTIONS 10
 - 4.1 Main Board Details: 10
 - 4.2 Backup Battery Connection 11
 - 4.3 Main Power Connection 11
 - 4.4 Detector Connections 12
 - 4.5 Prosense RS485 Serial Communication Module for Prosense Detectors 13
 - 4.6 Relay Outputs 14
 - 4.7 AUX Relay Output 15
- 5. FIRST RUN 15
 - 5.1 Automatic Test 16
- 6. PROGRAMMING 16
 - 6.1 Single Channel Mode: 17
 - 6.2 Setup Channel Parameters: 17
 - 6.3 Closing Unused Channels: 18
 - 6.4 Relay Assignment: 19
 - 6.5 Time Settings: 20
 - 6.6 Alarm Logs: 20
- 7. ALARM STATUS 21
 - 7.1 Checking Alarm and Fault Functions of Control Panel 21
 - 7.2 What To Do In Case Of Alarm 21
 - 7.3 Controlling the Alarm Fault Functions 22
- Declaration 23
- Warranty Statement 24

1. INTRODUCTION

Prosense DP32 Control Panel is able to provide automatic gas concentration reading and protection against gas explosions. DP32 permanently transmits the gas concentration measurement from detectors to the control unit. Before the gas concentration in the atmosphere reaches the L.E.L., the control panel is able to shut off a gas valve, cut off power and turn on an alarm via activating relays.

Prosense DP32 Control panel has three levels of alarm which are adjustable according to the measuring range and one fault alarm for the detection loop. Individual relays per function ensure remote controlled output. There are 4 relays on the panel. Two of them used as alarm relays and configured as ALARM-1 and ALARM-2. There is one FAULT relay and one AUX relay. The AUX relay can be defined as ALARM-1, ALARM-2 or ALARM-3. ALARM-3 is not a level based alarm but it is an alarm driven by digital input.

Prosense DP32 Control panel can manage 32 addressable gas detectors via RS485 serial communication. DP32 Control panel can manage explosive-flammable and toxic gas detectors as well as oxygen detectors with one RS485 serial cable to all detectors.

DP32 has 128x64 LCD screen on the front panel to show status of each detector. This LCD screen and menu keys allow user to set correct properties for each detector like gas concentrations by gas type, easement type, and range and alarm levels.

1.1 Technical Specifications

Power Source	220VAC +/-10%
Power Consumption	27VDC/250mA - 6.75W max. (without connected detectors)
Inputs (Internal)	1 serial input that can communicate to 32 detectors via RS485
Relay outputs	FAULT, ALARM1, ALARM2, AUX
Contacts rating	3A, 24VDC or 3A 120VAC
Display	Graphic LCD (128x64)
LED indicators	FAULT, ALARM1, ALARM2, AUX, BATT, POWER for overall status Power/On, Fault, Alarm LEDs for each detector
Backup battery	12V 7A/h (Optional)
Operating Temp.	0-50C ⁰
Humidity	15-85% non condensing
Housing	ABS IP66 (546 X 276 X 186 mm)
Weight	5,5 kg
Main power fuse	2A
Backup battery fuse	2A

Table 1: Technical specifications

1.2 Panel Dimensions

Panel dimensions are explained in Diagram 1:

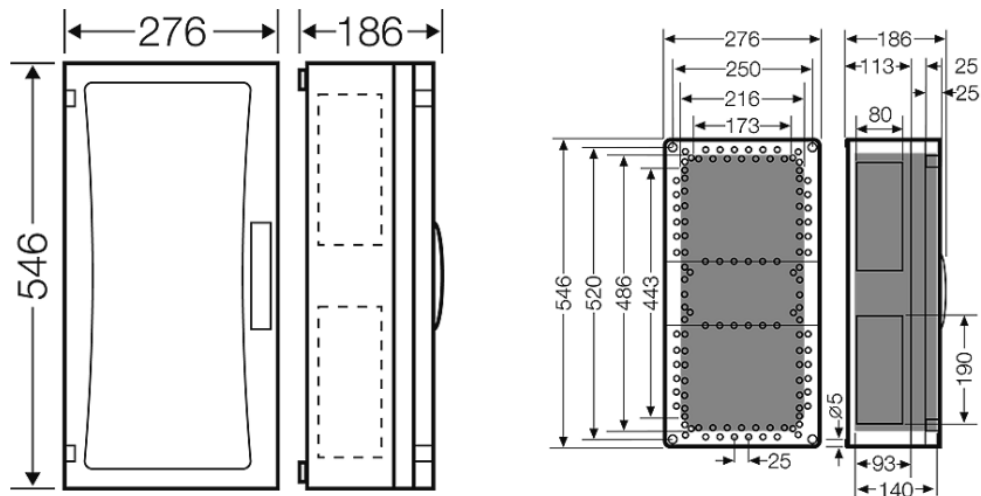

Diagram 1: Dimensions (mm)

2. INSTALLATION

The DP32 control panel box should never be placed in an explosive atmosphere and should be readily accessible. It is necessary to drill holes for cable glands either on the top or bottom of the control unit, depending on which side the electric cables are running in. Before drilling any holes you can unscrew and remove the electronic parts to avoid accidentally damaging it. DP32 control panel should not be placed nearby high voltage cables or power cable, coaxial cables or transmitters, welding stations or frequency regulators.

The DP32 panel box produced based on IP66 standard specifications. Always use the screw holes to mount it and do not pierce panel from any other side. Always use cable glands to make cable entries.

DP32 panel has 6 plastic screws on the front of panel. Use a flat screwdriver to lose them and remove the cover part on the front. Please take care and remove the connectors on the electronic card while removing the cover. Fix the panel on the wall via using 6 screw holes after removing the front cover. Reattached the front cover and tighten 6 plastic screws when wall mounting completed.

To prepare cable entries, remove plastic covers from top or bottom on the panel. Then drill the holes for cable entry and install cable glands to the holes you made it. Make sure you are using an adequate IP66 rate cable gland to assure the box ingress protection is not compromised. The panel box is modular and can be used with different assemblies. Prosense recommends having cable entries from the lower side. Electronic board is located in the front cover of the panel. The power supply is located at the back of panel box. The power

must be connected to this power supply. If the installation requires the connection to a backup battery, place the battery to lower right side of the panel inside.



Diagram 2: Panel cover plastic screw

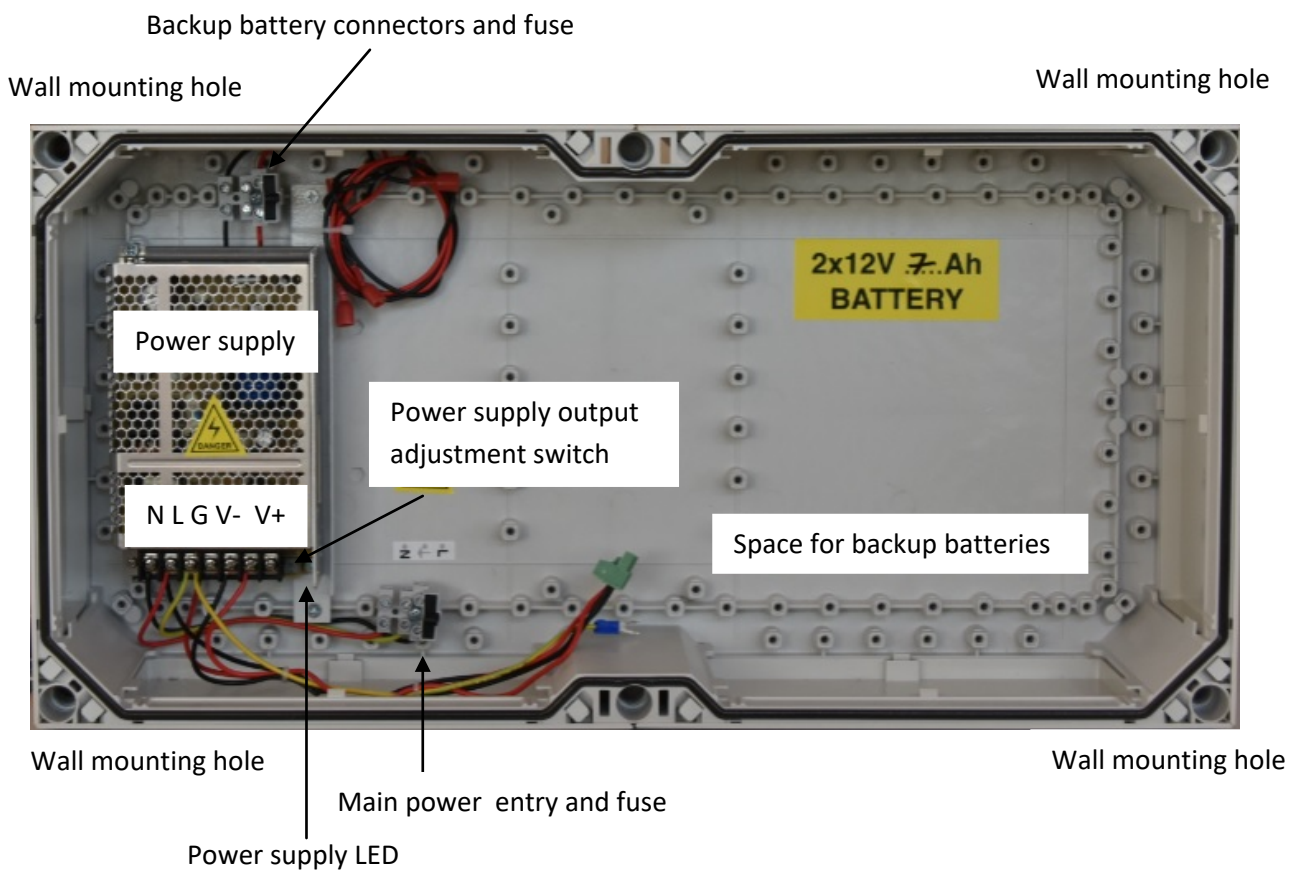

Diagram 3: Panel body

3. FUNCTIONS and DETAILS

The front panel has the following indicators as shown in Diagram 4:

Sign	Meaning
BATT	Battery in operation
AUX	AUX (assigned as ALARM1, ALARM2 or ALARM3*)
AL1	ALARM1
AL2	ALARM2
FAULT	Fault condition in at least one of the detector
POWER	220 VAC Operate
ON	Operation LED for each detector (8 green LEDs)
FAULT	Fault LED for each detector (8 yellow LEDs)
ALARM	ALARM LED for each detector (8 red LEDs)

Table 2: Front panel signs and meanings

*ALARM3 can only be activated when AUX relay assigned as ALARM3 on configuration menu and 24VDC Digital Input port configured to work with an outside device.

There are four buttons nearby LCD screen to perform configuration and display the detector details. Their functions are given in table (The key assignments may vary depending on the menu page):

Key	Function For Configuration	Function For Display Operation
MENU	Enter to panel configuration	OK - Select key
UP	Go to upper menu option during configuration	Go to the single channel details in normal operation
DOWN	Go to lower menu option during configuration	Page change on main screen
EXIT	Undo or exit from menu option	Reset on main screen

Table 3: Panel buttons and functions



Diagram 4: Front panel signs LCD and LEDs

DP32 Panel has 32 LEDs numbered from 1 to 32 nearby LCD panel. These LEDs will be activated in case of an alarm to show which detector is raising the alarm. If any of these LEDs are active it indicates the detector having that address has reached specified threshold level.

There is a front plastic cover to protect panel from outer shells, water and dust. To reach to panel first you need to open plastic cover via pressing both sides of the latches on the front. If panel ordered with keys a key needed to open plastic cover.

→ Press to open ←



Diagram 5: Front cover

If panel ordered with keys a key needed to open plastic cover.



Diagram 6: Front cover with key

In order to make panel connection, you need to open the front cover using the key at right bottom side of front panel. The key works clockwise and vice versa.



Diagram 7: Lock.

3.1 LCD Screen:

LCD screen shows time details and status of each detector connected to channels as shown in Diagram 8. As The LCD screen can show 6 lines at same time there are up to six pages that you can move via UP and DOWN buttons:

1	2	3	4	5
---	---	---	---	---

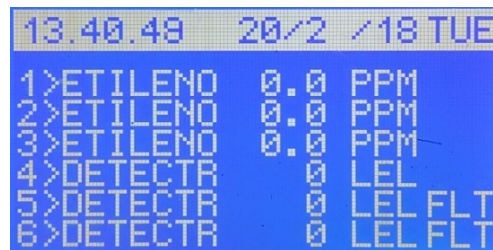

Diagram 8: LCD screen

The meaning of the signs used in LCD screen is given in Table 4:

Column	Sign sample	Meaning
1	1>	Channel number
2	DETECTR	Detector name (panel detects the name)
3	0.0	Gas level measured by detector
4	LEL	(LEL, VOL, PPM) measurement unit
5	A1	ALARM1 is active
5	A2	ALARM2 is active
5	FLT	FAULT status

Table 4: LCD screen details

If there is no detector connected to channel, LCD screen will show it as FLT and fault LED will be activated. That channel should be closed (deactivated) via using menu steps.

The LCD screen brilliance is adjustable by blue potentiometer shown in Diagram 9.

4. MAIN BOARD AND CONNECTIONS

4.1 Main Board Details:

DP32 Control panel has all connections on main board.

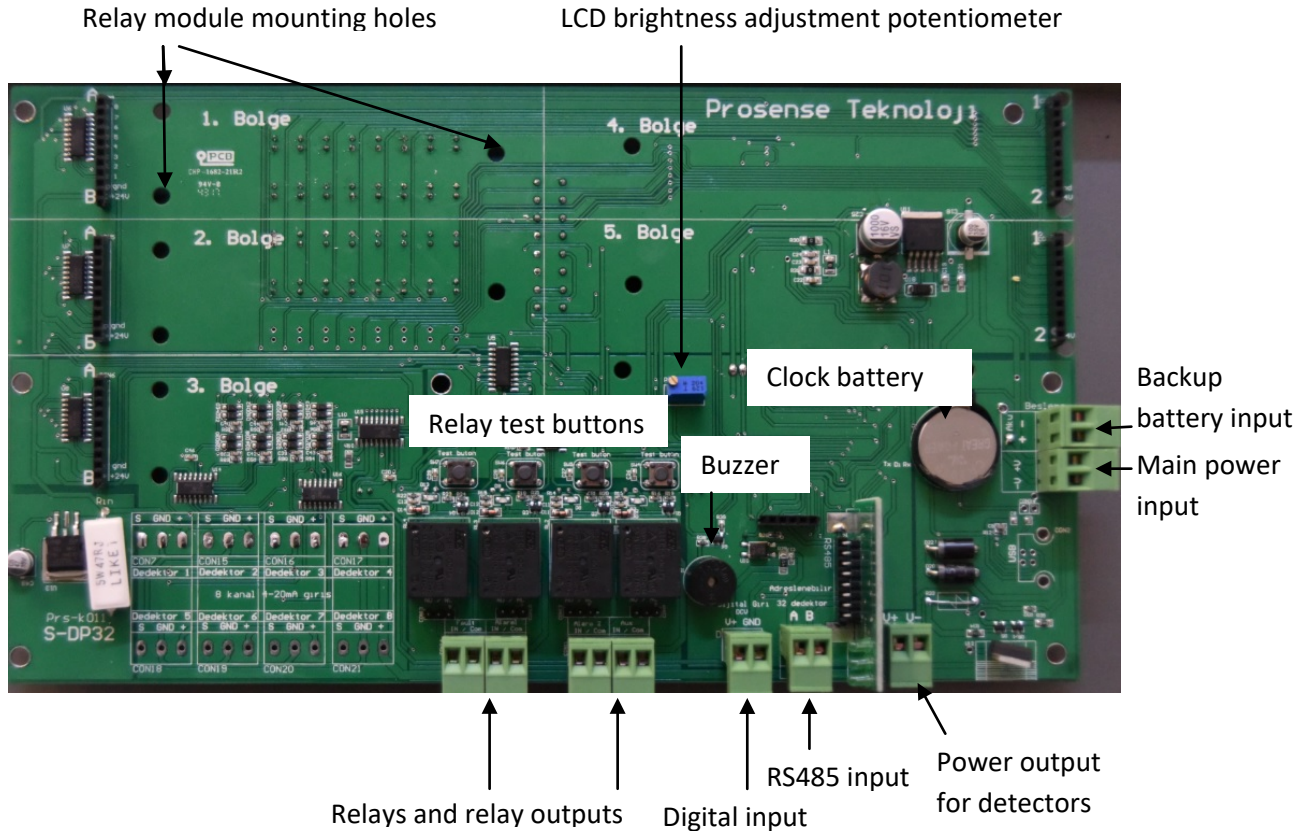

Diagram 9: Control panel main board

As shown in the picture, there is a 3V battery on the panel electronic board to keep data and time information. It should be replaced when it is run off.

There are five sockets on the main board to install optional relay modules. Each relay module has 8 relay on it and each relay controlled by one detector. It is also possible to take an independent output from each relay (each detector). The relay module install location should be used as follows:

1. Zone (1. Bölge): Not in use
2. Zone (2. Bölge): Alarm
3. Zone (3. Bölge): Alarm
4. Zone (1. Bölge): Alarm
5. Zone (1. Bölge): Alarm

There are 4 cube relays on main board and relay outputs can be taken from the terminals on the bottom of relays. The relays are used for Fault, Alarm 1, Alarm 2 and Aux outputs. There are test buttons at the top of each relay that can help to generate artificial alarms for testing purposes.

DP32 Panel has a buzzer on the main board to generate sound alarms. A digital input port provided on main board that should be 24VDC. To activate this input the AUX relay must be defined to work with digital input. Otherwise it does not provide any output.

Not: The electronic board may be warmed up when the panel is in alarm status for a long time.

4.2 Backup Battery Connection

To continue operation in case of main power failure two backup batteries (12V 7Ah) must be serially connected to the system. Take extra care to connect the batteries with correct poles. The cables or main board can be damaged in case of mixing pins or making short circuits. Backup batteries must be connected as shown below.

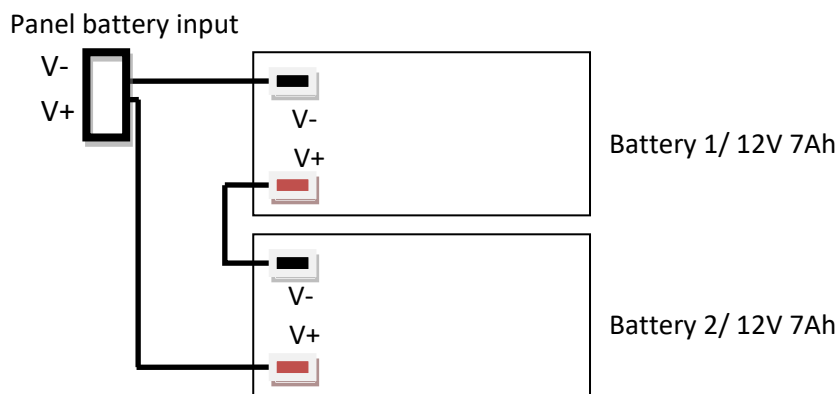

Diagram 10: Backup battery connection

4.3 Main Power Connection

Connection must be made three-wire 1.5mm² cross section cable to the main supply terminal entries and fixed by using cable fastener on the terminal. Make sure all the detectors connected properly before applying the power.

Name	Type	Usage
L	input	Phase
Gnd	input	Ground
N	input	Neutral
V+	output	+24VDC (Only for panel and detectors, do not use for any other device)
V-	output	-VDC

Table 5: Main power connection details

4.4 Detector Connections

DP32 Panel can be connected and monitor 32 detectors with RS485 serial connection. V+, V- (GND), A and B ports must be connected via using four-wire cable. Detector connections supply 27VDC power to detector and read the output signal of detector from A and B ports. Thus connections should be made correctly to do not cause any damage on the detectors. Detector power connection should be done with 1.5mm² cross section cable. The total distance between control panel and detectors should not exceed 800 meters. Detector connections should be made with 4 core cable wire that 2 for power and 2 for RS485 and pin definitions are as follows:

V+	output	+24VDC (Only for panel and detectors, do not use for any other device)
V-	output	-VDC
A	input	RS485 port A
B	input	RS485 port B

Table 6: Connection pin definitions

The wiring for detectors utilized with RS485 board should be done by using connection cable EIA RS485 2 core wires with section 0.22 / 0.35 mm² and shielded. Nominal capacity between the wires should be < 50pF/m and nominal impedance should be 120 Ohms.

The V+, V- ports and A, B ports are located different sockets in DP32 main board. These ports are formed in same or different sockets on Prosense detector address modules. The connections should be done with care to do not mix power and RS485 ports. All detectors will be connected through one cable via hopping one detector to another till the last detector on the line. The connection schema is given in Diagram 11:

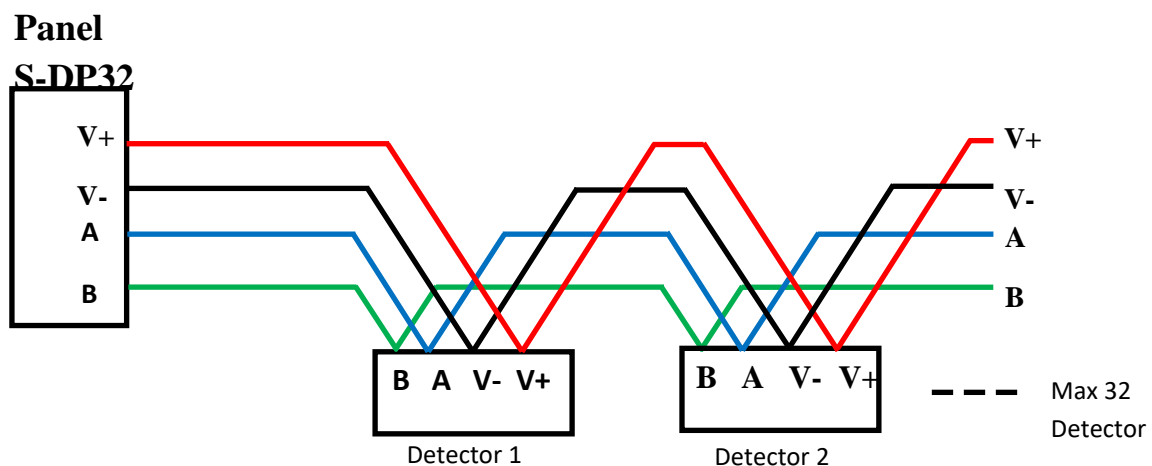

Diagram 11: Panel to detector connections

There should be one master device and up to 32 slave devices in RS485 communication. The master is DP32 control panel and detectors will be the slave devices:

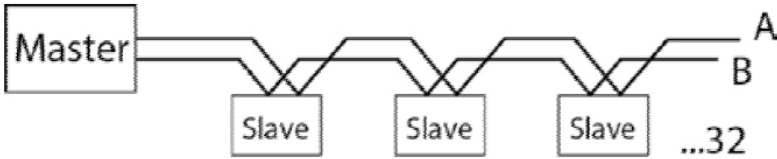

Diagram 12: RS485 communication

Each detector connected to same DP32 panel should have unique address. Detectors having same address would not be recognised by control panel. DP32 panel can communicate up to 32 detectors. In case less than 32 detectors connected, control panel would not show non-existent detectors. Unused detectors should be deactivated on channel settings menu steps.

The **last** detector at the RS485 serial line should have the end of line resistor to enable the total communication line. Otherwise control panel may not communicate to all, some or none of the detectors. The end of line resistor controlled by end of line pins located on address module of Prosense detectors and can be enabled via putting the jumper on end of line pins. Details are given in section 3.5.

4.5 Prosense RS485 Serial Communication Module for Prosense Detectors

Prosense produce a communication module to enable RS485 Modbus serial communication. The board has 4 ports thus the detector connection should be made by 4 wire that 2 for power and 2 for RS485. The total length of the connection line should not exceed 800 meters.

The wiring for detectors utilized with RS485 board should be done by using connection cable EIA RS485 2 core wires with section 0.22 / 0.35 mm² and shielded. Nominal capacity between the wires should be < 50pF/m and nominal impedance 120 Ohms.

Detectors will be wired in daisy chain (bus) mode. We recommend not using star mode connection due to negative impact of interference. Each detector should have unique address number in the chain. The detectors would not be recognised by control panel if same address given to them. The address of detector can be adjusted via using DIP-Switch set on the board:

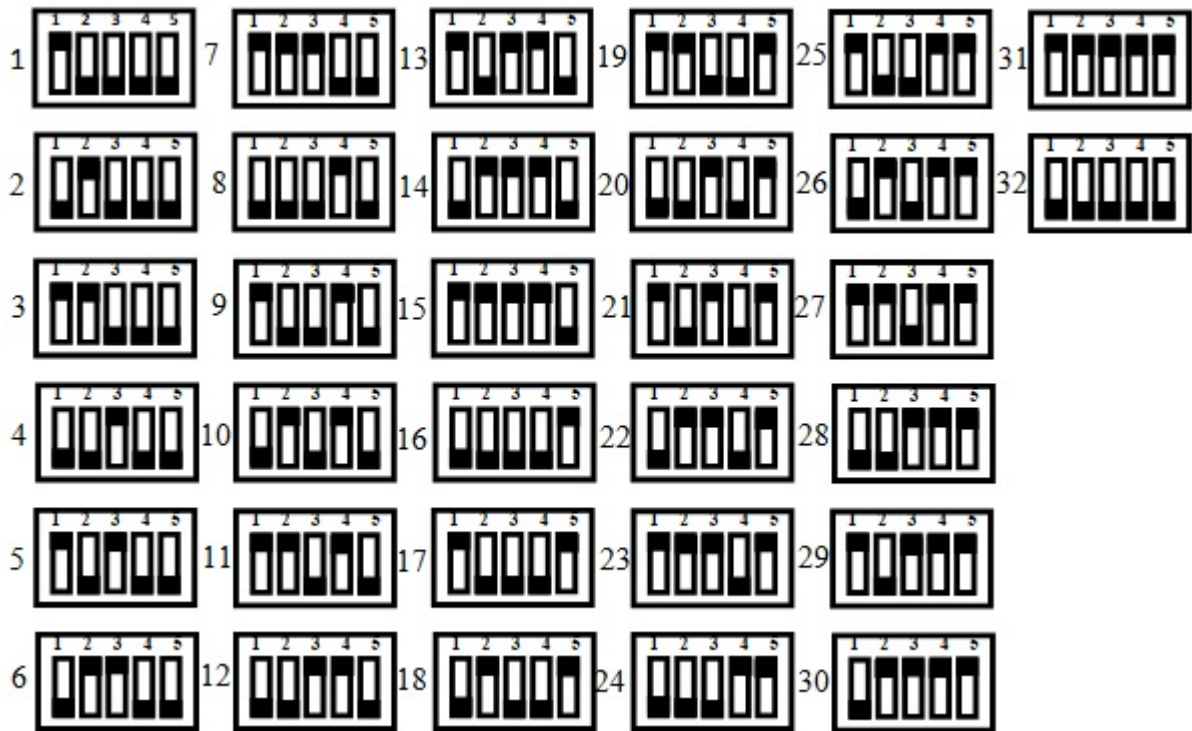

Diagram 13: RS485 Modbus serial communication address and switch position

The last detector in the chain should have 120 Ohms RS485 termination resistor. The resistor is already implemented on the board by default but not activated. User should activate the termination resistor via using the termination pin once the installation completed.

Important: Only the last detector on the serial bus should have end of line pin.

For more details please check detector user manuals.

4.6 Relay Outputs

DP32 panel without any optional relay modules has four relay outputs which are ALARM1, ALARM2, FAULT and AUX and connection ports are located right under the relays.

Relay activation rules:

ALARM1: This relay will be activated when any of the detectors in the system will exceed the programmed A1 level. If there is oxygen detector used in the system, ALARM1 is also used as the lower alarm level.

ALARM2: This relay will be activated when any of the detectors in the system will exceed the programmed A2 level. If there is oxygen detector used in the system, ALARM2 is also used as the higher alarm level.

FAULT: This relay will be activated when any of the detectors in the system is in fault status.

The active relays can also be monitored via related LEDs on the panel.

If needed user can obtain independent alarm and fault outputs from each detector via using optional relay module. Relay modules should be installed reserved zone sockets explained earlier. The relays are configured as NO (normally open) by default at factory. The relay configurations can be adjusted via putting jumpers under each relay. Relay will not provide output while jumpers are omitted or not installed.

Relay connections pins:

NC : Normally closed contact pin (Select by jumper under relay)

NO : Normally open pin (Select by jumper under relay)

COM : Common pin

Not: Relays should not be connected to devices using high current or more than 24V loads. The relay outputs should be used as control signal and external relays should be used to drive such devices as relay on main board cannot handle high load.

4.7 AUX Relay Output

Aux relay can be programmed from the main menu on the panel to match to ALARM1, ALARM2 or ALARM3. When ALARM1 is selected, AUX relay will operate simultaneously with ALARM1 relay of the system. When ALARM2 is selected, AUX relay will active when ALARM2 relay activated. When ALARM3 is selected, AUX relay will be activated by the digital input on the panel.

5. FIRST RUN

After power applied to panel manufacturer (Prosense) and model (DP32) will be seen on LCD screen:



The panel will start searching channels one by one and activate the power and fault LEDs. This operation may take two minutes. During this period, system will operate in standby mode until the detectors are warmed up. Instantaneous alarms will be turned off when the first energy is applied.

LCD screen will display the list of recognised detectors, when standby time period complete. If all detectors recognised and communicating with the panel the fault LED would be turned off. Time and date information will appear at the top of the screen. The date and time information is stored by battery on the control panel board. It should be adjusted via using menu steps if it is not correct.

5.1 Automatic Test

DP32 gas control panel simultaneously monitor all detectors connected to it. If any of the detectors raise an alarm panel alarm relay(s) and the alarm LED for the detector raising the alarm would be activated. Alarm and fault status can be monitored on LCD screen.

6. PROGRAMMING

The panel is already programmed and ready for using when shipped. User should adjust the alarm settings via changing alarm levels for each detector depending on the installed detector specifications. Each detector should be defined independently to related detectors measurement unit and scale as well as alarm levels. These adjustments can be done via using the keys nearby LCD screen. The menu content and step flow are given in Diagram 14.

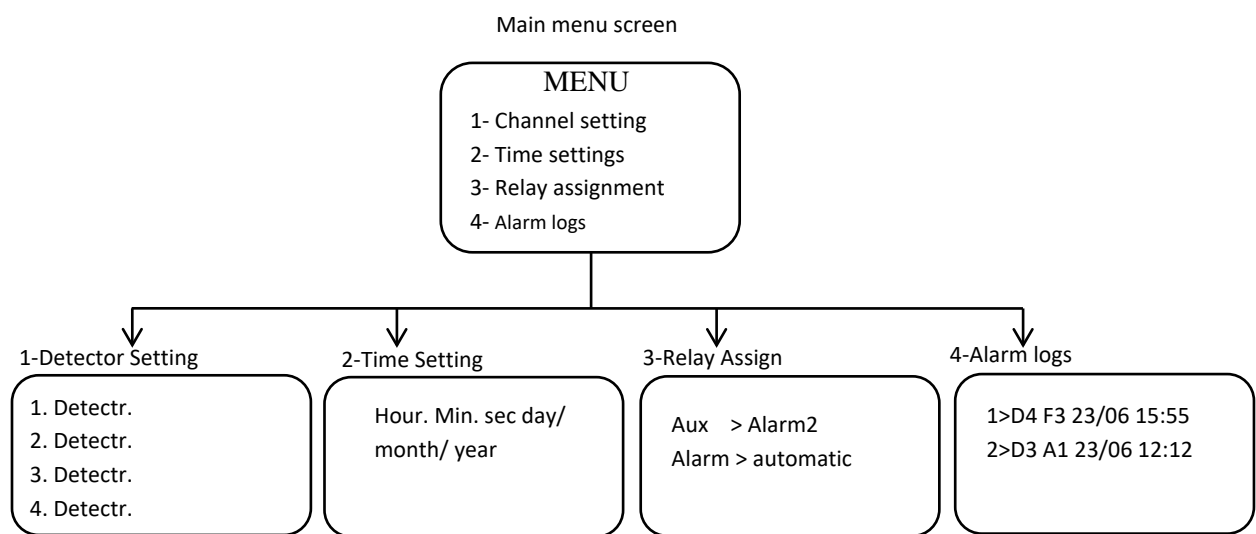

Diagram 14: Menu structure

DP32 control panel keeps data and time information to record alarm events in the internal log space. Date and time displayed on the main screen and can be adjusted from the main menu when needed.

The unused channels on the panel should be switched off via the menu. Otherwise it will be shown in fault status on panel.

To activate configuration menu, press and hold the MENU button for 1 second. You can navigate between the menu items via using the UP and DOWN keys

1. Channel setting
2. Time settings
3. Relay assignment
4. Alarm logs

When you reach the desired menu item, press the MENU key again to enter submenu. You can EXIT from submenu or menu by pressing the EXIT button.

6.1 Single Channel Mode:

To see each detector status in detail, press UP button on the main menu. Screen will switch in to single channel mode. Then it will display detector status, instant reading value, alarm status and detector name:

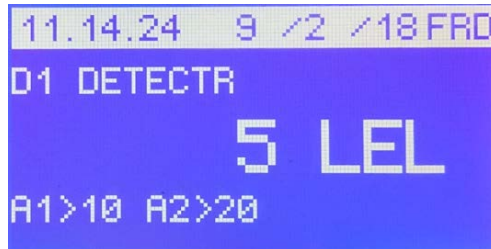

If there is any fault or alarm it will be displayed right bottom corner of screen:

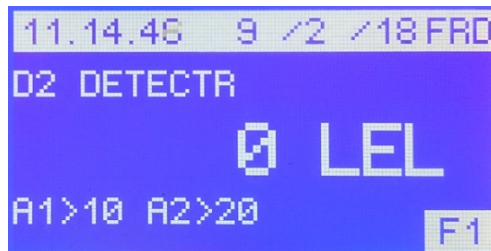

You can switch between channels via using UP or DOWN buttons. Also you can directly reach alarm logs screen via pressing MENU button in single channel mode. Logs keep alarm and fault details with their date and time for last 24 hours. You might use UP and DOWN buttons to see all records. Press EXIT button to return main menu. Screen will automatically exit from the single channel menu to main menu after 2 minutes if there is no user action.

6.2 Setup Channel Parameters:

To adjust channel parameters follow below steps.

1- Press Menu button for 2 seconds. The screen will display menu options:



2- Select Channel setting via pressing the MENU button. Screen will list channels:

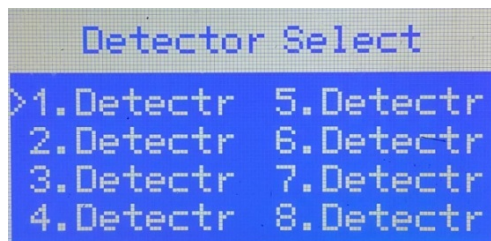

3- Move desired Channel from the list via using UP and DOWN buttons and press MENU button to select channel. A new menu will display with below options:

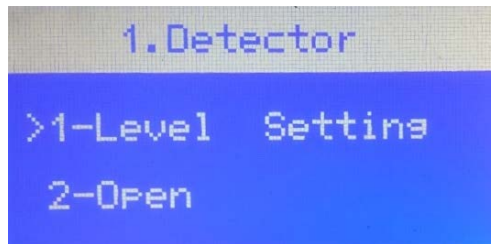

4- To adjust alarm level settings select "Level Settings" option. DP32 panel automatically detect the detector measurement range and unit. Hence it will display the unit detected. It is not possible to change the unit manually:

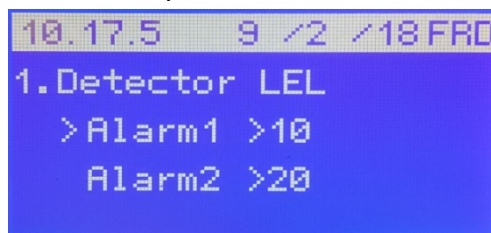

When press MENU button a cursor will be located under Alarm1 level. You can adjust alarm level via using UP and DOWN buttons.

5- Then press EXIT button to release the cursor.

6- Then you can move Alarm2 via using UP or DOWN buttons.

7- Press MENU button again to activate cursor and adjust level using UP and DOWN buttons.

8- Once all completed press exit button to return the previous screen.

Alarm1 level would not be increased higher than Alarm2 level. So if you want to increase alarm levels it would be easier to adjust first Alarm2 level then adjust Alarm1 level.

9- Once all completed press EXIT button to return main menu.

6.3 Closing Unused Channels:

Unused channels should be deactivated if not all channels used on control panel. Otherwise unused channels and control panel will stay in fault status. To deactivate unused channel go to the Channel Settings menu via pressing the MENU button. Then move related channel via using UP and DOWN buttons and select channel with MENU button. You will see the below detailed settings menu:

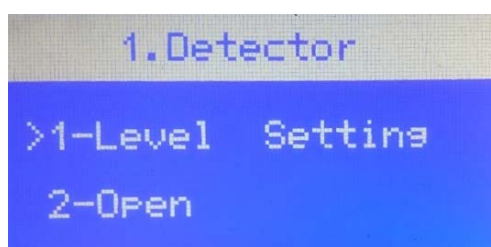

The second step on this menu pointing the actual status of the channel. "Open" means channel is active. To close this channel move to the option 2 on screen via UP and DOWN

buttons then press MENU button to change status. It will be deactivated and shown like below:

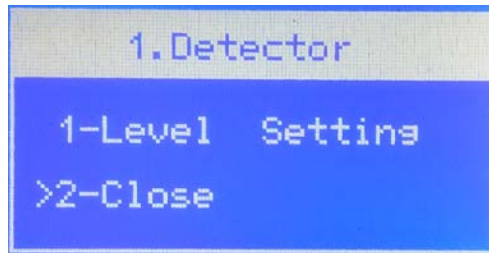

6.4 Relay Assignment:

The relays have two status mode; locked and automatic. The mode selection should be done while channel setup done. When automatic mode selected the relays will be deactivated when alarm condition cleared. Once the gas is detected, the environment should be cleaned to return to normal operation. Then relay will be deactivated automatically.

When latching mode selected, the relay will not release and stay in active mode till manual intervention. Even after environment is cleaned following an alarm condition, the relay will stay active when used in latching mode. User should release them via pressing the EXIT button for 2 seconds. If gas still exists in environment, pressing the EXIT button will reset and stop alarms for a moment. Then they will be activated again as gas still exist in the environment.

To change relay assignment press MENU button on main screen and select “Relay Assign” option. The screen will display default working mode for all relays and assignment for AUX relay:

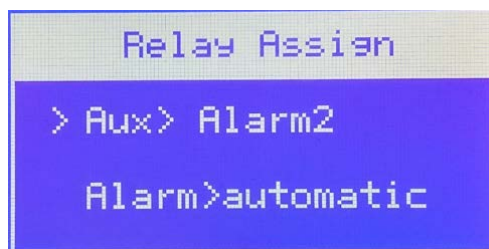

Press MENU button to change AUX relay assignment. A cursor will be activated on the screen and you can change assignment via using UP and DOWN buttons. Once complete press EXIT button to save and return the screen.

Use UP and DOWN buttons to move Alarm line on screen. Then press MENU button again to change relay mode. A cursor will be shown on screen and you can select the mode automatic or latching via using UP and DOWN buttons:

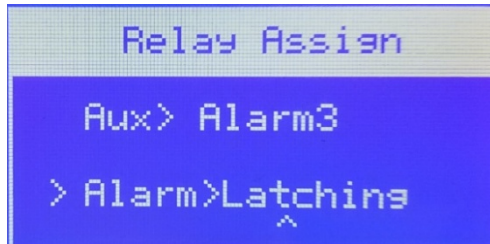

Once decided press EXIT button to return to main screen.

When AUX relay assigned to ALARM3, Digital Input port will be monitored on the panel and AUX relay will be activated once the digital input activated by external device.

6.5 Time Settings:

To change time and date press MENU button and select “Time Settings” option. A new menu will be displayed including time and language options:



Press MENU button to adjust time. A new screen will display current time and date information on the control panel.

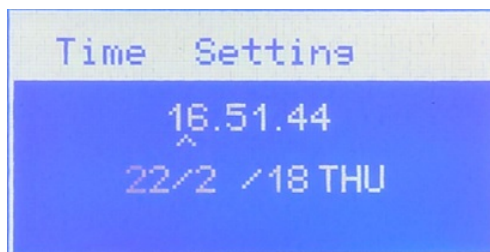

Use UP, DOWN and MENU buttons to change value and move to the next item on the screen. Once completed press EXIT button to return to settings screen.

6.6 Alarm Logs:

To see recorded alarm and fault logs press MENU button and select “Alarm Logs” option.



A new menu will be displayed listing the recorded logs. The alarm logs recorded once the alarm detected with the information below:

- Detector addresses (D1, D2, D3 ...)

- Fault type code given below:

 - F3: Connection Error

 - F4: Detector Fault

 - A1: Alarm-1

 - A2: Alarm-2

- Date and Time of the error recorded

Alarm logs cannot be deleted. Panel program will overwrite if there is no space available when new logs received. Use UP, DOWN and MENU buttons to see all recorded logs via changing the window. Once completed press EXIT button to return to main menu.

7. ALARM STATUS

There is one alarm LED for each detector. In addition to them there are two alarms, one fault, one power and one battery LEDs used to monitor overall panel status.

ALARM1 and ALARM2 LEDs will be activated and kept active when any of the detectors raised an alarm. The LED will be activated for related detector in case of alarm to understand which detector is reporting the alarm. The LEDs and related relay outputs will be active when the detector reaches the defined alarm threshold level.

7.1 Checking Alarm and Fault Functions of Control Panel

The main board has 4 test buttons on top of each relay to generate false alarm and test relay function. Each relay function can be tested by pressing to related test button. The relay will be activated while pressed the test button and deactivated when button released.

Important: Test buttons do not provide functionality to check that the control unit will actually react at a specific gas concentration. This can only be achieved by applying a calibration gas on the detector.

7.2 What To Do In Case Of Alarm

Refer to the mandatory safety procedures (gas alarm) set forth by your safety manager. Recommendations:

Keep calm and follow these instructions:

1. Put out all naked flames (including cigarettes, pipes, etc.)
2. Turn off all gas appliances.
3. Turn off the gas supply at the tap and/or on the gas bottle (in the case of LPG).
4. Do not switch electrical appliances, lamps or the gas detection control unit on or off.
5. Open all windows and doors to air the room.
6. Do not "reset" the control unit if it is in the same room.

If the gas concentration reading on the control unit does not fall below the level of alarm, and the reason for the gas leak is not immediately apparent and/or cannot be repaired, quit the premises and call the gas supplier and/or emergency services immediately to check the installations and to make the premises safe and to possibly carry out the necessary repairs. If the alarm stops and the reason for the alarm is identified and resolved (e.g. a kitchen burner lit off but in the open position) the gas supply may be re-opened after checking that all the gas appliances are off.

7.3 Controlling the Alarm Fault Functions

	PROBLEMS	POSSIBLE CAUSES	WHAT TO CHECK
1	The display is not on	Main power source is OFF	Check the Main power connection
		Bad power supply.	Check the power supply. The green LED should be on
		Blown fuse(s).	Check fuses on main power connection and replace if necessary.
2	BATTERY LED is ON	Backup battery is empty	Check Battery voltage with voltmeter
		Power supply range is below 27 V	Adjust power supply output level via Phillips screwdriver
3	FAULT LED is ON and FLT sign shown on LCD screen	The Detector connection is broken	Check the detector cables
		The detector output current is too low	If detector is working fine the output current might be getting low at control panel input. Adjust the zero level of the detector.
		There is no detector connected to channel	Close (deactivate) related channel via using menu steps
4	ALARM1 and/or ALARM2 and/or AUX LED is ON	There is a gas leak.	Close the manual valve on the gas input pipe. Locate and repair the leak.
5	ALARM1 and/or ALARM2 and/or AUX LED is ON and there is no gas leak	The control panel has false alarms	Reset the control panel via power off / Power on
		Alarms might stuck due to previous gas leak	Press EXIT button for 5 seconds to reset the panel

Table 7: Problems and possible causes

Declaration



Manufacturer Declaration of Conformity



Prosense Teknoloji San Ltd. Şti declares the DP Series products to be in accordance with the following standards and directives.

Name and address of Manufacturer: Prosense Teknoloji San Ltd Şti
Cumhuriyet Mah. Mermer Sok No:16
34876 - Kartal - İstanbul - Türkiye

Description of Devices: DP Series Fixed Type Gas Control Panel

Designation: [Ex Gb] IIC

Applied Harmonized international standards:

- IEC EN 60079-0:2017 (Ed. 7.0) Equipment – General requirements
- IEC EN 60079-29-1: 2016 (Ed. 2.0) Gas detectors – Performance requirements of detectors for flammable gases
- IEC EN 50271:2018: Electrical apparatus for the detection and measurement of combustible gases, toxic gases or oxygen - Requirements and tests for apparatus using software and/or digital technologies

Applied European Directives:

- 2014/ 30/ EU Electromagnetic Compatibility (EMC)
- 2014/ 35/ EU Low Voltage (LVD)

DP Series Fixed Type Gas Control Panel complies to below rules given in IEC EN 60079-29-1:

- Unpowered storage (§5.4.2 IEC 60079-29-1)
- Calibration and adjustment (§5.4.3 IEC 60079-29-1)
- Alarm set point(s) (§5.4.5 IEC 60079-29-1)
- Temperature test (§5.4.6 IEC 60079-29-1)
- Vibration test (§5.4.12 IEC 60079-29-1)
- Warm-up time (§5.4.14 IEC 60079-29-1)
- Time of response (§5.4.15 IEC 60079-29-1)
- High gas concentration operation above the measuring range (§5.4.16 IEC 60079-29-1)
- Power supply variations (§5.4.18 IEC 60079-29-1)
- Verification of software and digital components (§5.4.23 IEC 60079-29-1)
- EMC Test performed according to Tab.2 of IEC 61326-1:2012

Each DP Series gas control panel device which Production Quality Assurance procedures and Type Examination procedures have been applied has been shown to conform to an approved Type and to the applicable classification rules and essential principles before being supplied. This declaration is being made on the basis of the following certificates:

Production Quality Assurance Certificate: ExVeritas 18PQAN0072

Authorized Signatory: **Firat Celep**
Production Manager

Date: 05.03.2020

Warranty Statement

All products are designed and manufactured to the latest internationally recognized standards by Prosense Technology under a Quality Management system that is certified to ISO 9001. As such Prosense Technology warrants its products against defective parts and workmanship and will repair or (at its option) replace any instruments which are or may become defective under proper use within 12 months from date of commissioning by an approved Prosense Technology representative or 18 months from date of shipment from Prosense Technology, whichever is the sooner. This warranty does not cover disposable batteries or damage caused by accident, abuse, abnormal operating conditions or poisoning of sensor.

Defective goods must be returned to Prosense Technology premises accompanied by a detailed description of any issue. Where return of goods is not practicable Prosense Technology reserves the right to charge for any site attendance where any fault is not found

with the equipment. Prosense Technology shall not be liable for any loss or damage whatsoever or howsoever occasioned which may be a direct or indirect result of the use or operation of the Contract Goods by the Buyer or any Party.

This warranty covers instrument and parts sold to the Buyer only by authorized distributors, dealers and representatives as appointed by Prosense Technology. The warranties set out in this clause are not pro rata, i.e. the initial warranty period is not extended by virtue of any works carried out there under.

In no event will Prosense Technology be liable for any incidental damages, consequential damages, special damages, punitive damages, statutory damages, indirect damages, loss of profits, loss of revenues, or loss of use, even if informed of the possibility of such damages. Prosense Technology's liability for any claims arising out of or related to this product will in no case exceed the order value. To the extent permitted by applicable law, these limitations and exclusions will apply regardless of whether liability arises from breach of contract, warranty, tort (including but not limited to negligence), by operation of law, or otherwise.