



PROSENSE S-DP8 Gas Control Panel User Manual



Prosense Teknoloji San. Ltd. Şti.
Cumhuriyet Mah. Mermer sok. No:16 Kartal İstanbul
Tel: (90) 216 306 77 88 Faks: (90)216 473 81 29
www.prosense.com.tr

WARNING!
READ THIS INSTRUCTION FIRST!

This manual must be carefully read by all persons who have or will have the responsibility for installing, using or servicing this product.

Like any equipment, this product will perform as designed only if installed, used and serviced in accordance with the manufacturer's instructions. Otherwise, it could fail to perform as designed and persons who rely on this product for their safety could suffer severe personal injury or death.

The warranties made by Prosense with respect to this product are voided if the product is not installed, used and serviced in accordance with the instructions in this user guide. Please protect yourself and other by following them.

WARNING!

Inductive or capacitive loads like motors, ventilation, e.g. should not be directly connected to the panel directly. In such cases, auxiliary external relays should be use to drive these loads.

Contents

- Introduction 4
- Technical Specifications 5
- Panel Dimensions 6
- Installation..... 6
- Functions 9
 - LCD Screen:..... 10
 - Special States..... 10
 - Fault Status:..... 10
 - Overrange Status:..... 11
 - Alarm Status: 11
- Main Board and Connections 12
 - Main Board Details: 12
 - Backup Battery Connection 13
 - Main Power Connection 13
 - Detectors Connections 14
 - Relay Outputs 14
 - AUX Relay Output 15
- First Run..... 15
 - Automatic Test 15
- Programming..... 16
 - Setup Channel Parameters:..... 16
 - Closing Unused Channels: 18
 - Relay Assignment: 19
 - Time and Language Settings:..... 20
- What to Do In Case of Alarm 21
 - Checking Alarm and Fault Functions 21
 - Controlling The Alarm Fault Functions 22
- Prosense Panel Monitor Software Option 22
- Declaration 23
- Warranty Statement..... 24

Introduction

Prosense S-DP8 Control Panel is able to provide automatic gas concentration reading and protection against gas explosions. S-DP8 permanently transmits the gas concentration measurement from detectors to the control unit. Before the gas concentration in the atmosphere reaches the LEL, the control panel is able to shut off a gas valve, cut off power and turn on an alarm via activating relays when correctly integrated to related control devices. Prosense S-DP8 Control panel can manage 8 analogue 4-20mA output gas detectors. S-DP8 Control panel can manage explosive-flammable and toxic gas detectors as well as oxygen detectors with direct connection to each detector via standard 4-20mA output.

Prosense S-DP8 Control panel has two levels of alarm which are adjustable according to the measuring range and one fault alarm for the detection loop. Individual relays per function ensure remote controlled output. There are 4 relays on the panel. Two of them used as alarm relays and configured as ALARM-1 and ALARM-2. There is one FAULT relay and one AUX relay. The AUX relay can be defined as ALARM-1, ALARM-2 or ALARM-3. ALARM-3 is not a level based alarm but it is an alarm driven by digital input connected to another external device.

S-DP8 has 128x64 LCD screen on the front panel to show status of each detector. This LCD screen and menu keys allow user to set correct properties for each detector like gas concentrations by gas type, measurement unit, and range and alarm levels.

S-DP8 Gas Control Panel complies to IEC 60079-0:2017 and IEC 60079-29-1:2016 standard requirements. Please refer to the certification label on the control panel to identify the type of certification that relates to the product supplied.

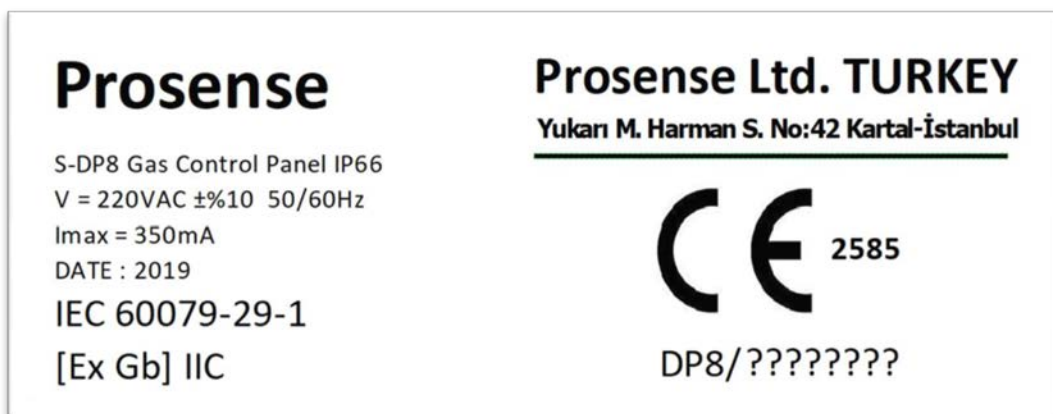

Diagram 1:Panel Label

The serial number of the product given with “DP8/?????????” numbers.

Technical Specifications

Power Source	220VAC ±10% 50/60 Hz
Power Consumption	27VDC/250mA - 6.75W max. (without connected detectors)
Inputs (Internal)	8 Analogue 4-20mA
Relay outputs	FAULT, ALARM1, ALARM2, AUX
Contact ratings	3A 24VDC or 3A 120VAC
Display	Graphic LCD (128x64)
LED indicators	FAULT, ALARM1, ALARM2, AUX, BATT, POWER for overall status
	Power/On, Fault, Alarm LEDs for each detector channel
Backup battery	12V 7A/h (Optional) X 2
Operating Temp.	-10 : 60C ⁰
Humidity	15 : 95% non condensing
Housing	ABS IP66 (546 X 276 X 186 mm)
Weight	5,75 kg
Main power fuse	2A
Backup battery fuse	2A
Warm-up time	Up to 2 minutes
Delay time	Panel can recognize any special state in 2 minutes
Special States	Fault (Fault Relay de-energised)
	Overrange (Alarm Relay(s) energised)
EMC conformity	EN 61326-1 Group-1 Class-A
IEC conformity	IEC 60079-29-1:2106
Program Release	V3.02
Special condition	Do NOT install in hazardous area

Table 1: Technical specifications

Panel Dimensions

Panel dimensions are explained in Diagram 1:

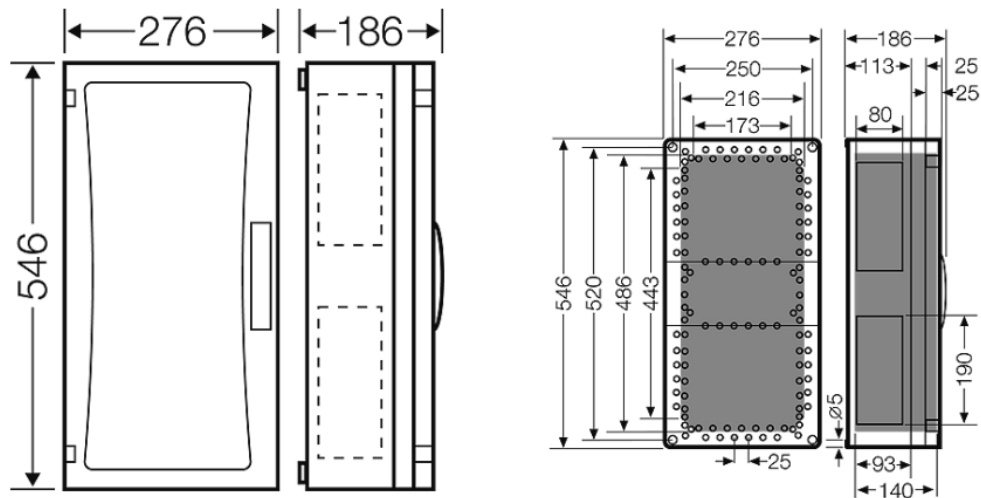

Diagram 2: Dimensions (mm)

Installation

The S-DP8 control panel box should never be placed in an explosive atmosphere and should be readily accessible. It is necessary to drill holes for cable glands either on the top or bottom of the control unit, depending on which side the electric cables are running in. Please unscrew and remove the electronic parts before drilling to avoid any accidentally damaging. S-DP8 control panel should not be placed nearby high voltage cables or power cable, coaxial cables or transmitters, welding stations or frequency regulators. The S-DP8 panel box produced based on IP66 standard specifications. Always use prepared screw holes to mount it and do not pierce panel from any other side. Always use suitable cable glands to make cable entries.

There is a front plastic cover to protect panel from outer shells, water and dust. To reach to panel first you need to open plastic cover via pressing both sides of the latches on the front. If panel ordered with keys a key needed to open plastic cover.

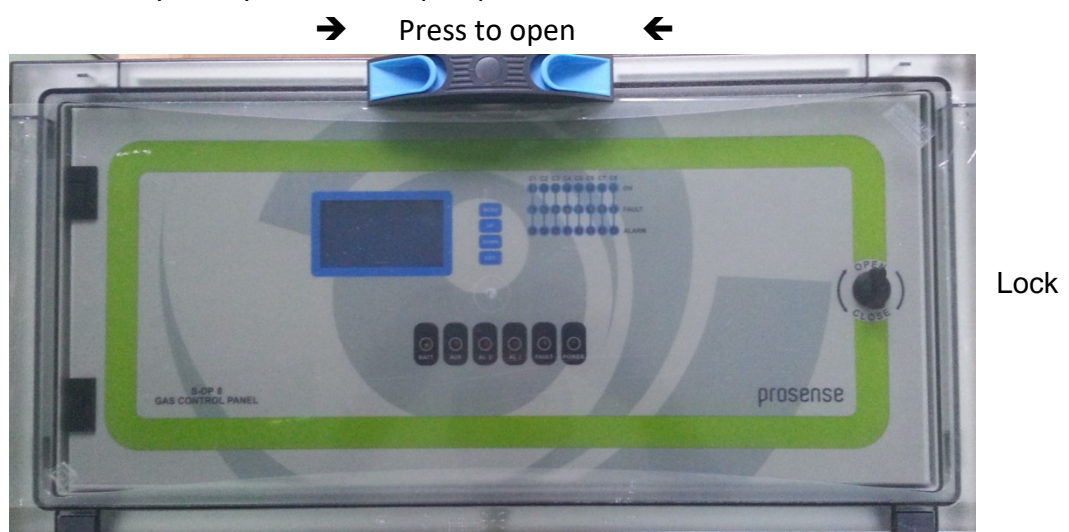

Diagram 3: Front cover

If panel ordered with keys a key needed to open plastic cover.



Diagram 4: Front cover with key

In order to make panel connection, you need to open the front cover using the key at right bottom side of front panel. The key works clockwise and vice versa.



Diagram 5: Locker.

S-DP8 panel has 6 plastic screws keeping panel door in place in front of panel. Use a flat screwdriver to lose them and remove the panel door assembly. Please take care and remove the connectors on the electronic card while removing the cover. Fix the panel on to the wall via using 4 screw holes in each corner after removing the front cover. M4 screws are suitable to fix the panel body to the wall. Once wall mounting completed reattached the front cover and tighten 6 plastic screws.

To prepare cable entries, remove plastic cover from top or bottom on the panel. Then drill the holes for cable entry and install cable glands to the holes you made it. Make sure you are using an adequate IP66 rate cable gland to assure the box ingress protection is not compromised. The panel box is modular and can be used with different assemblies. Prosense recommends having cable entries from the lower side. Electronic board is located in the front cover of the panel. The power supply is located at the back of panel box. The power must be connected to this power supply. If the installation requires the connection to a backup battery, place the battery to lower right side of the panel inside.

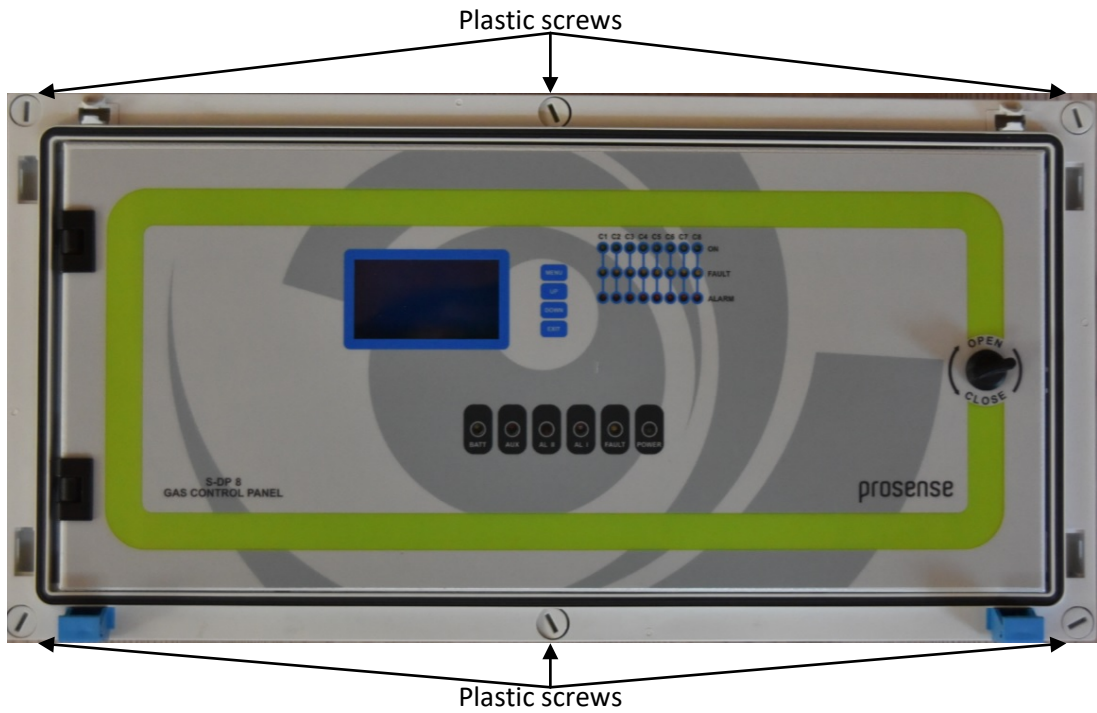

Diagram 6: Panel cover plastic screw

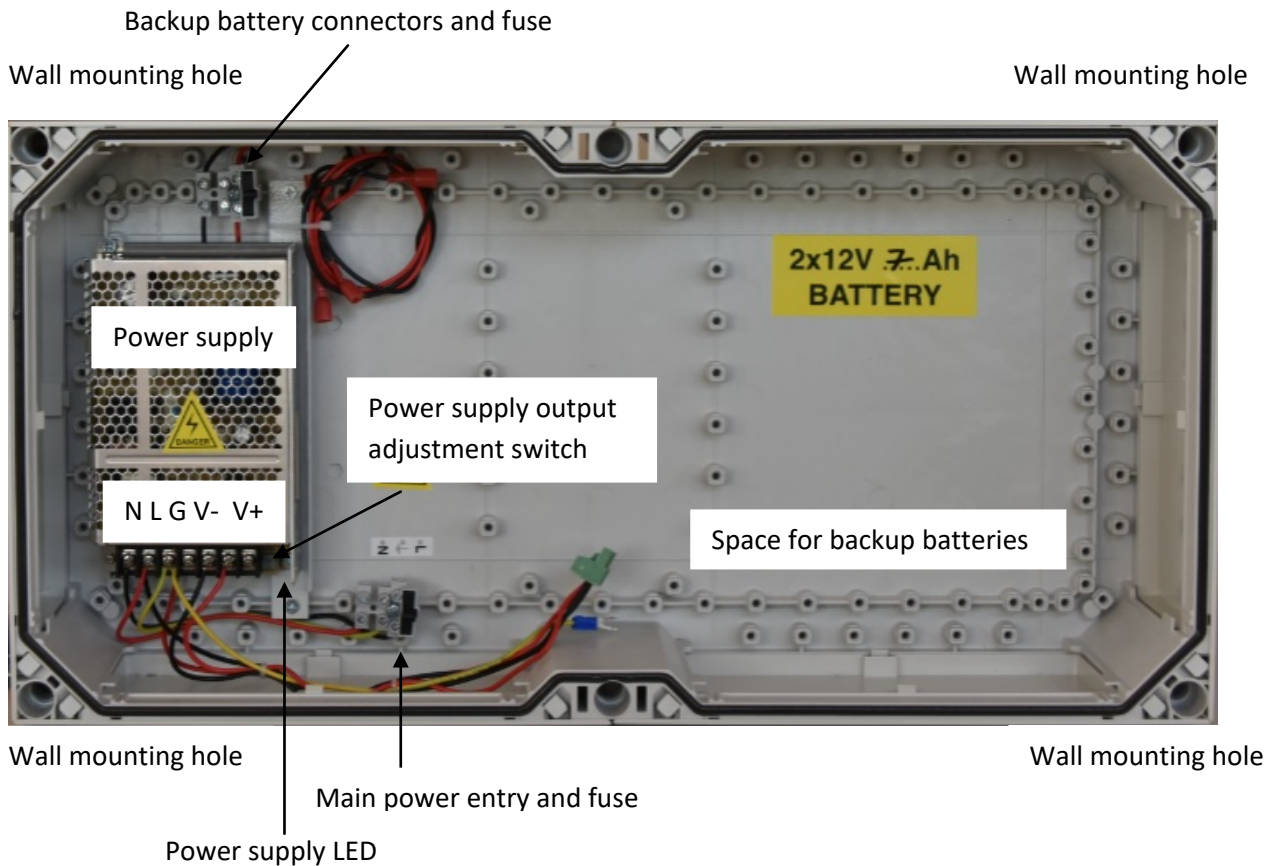

Diagram 7: Panel body

Functions

The front panel has the following indicators as shown in Diagram 4:

Sign	Meaning
BATT	Main Power lost, Battery in operation
AUX	AUX (assigned as ALARM1, ALARM2 or ALARM3*)
AL1	ALARM1
AL2	ALARM2
FAULT	Fault condition in at least one of the detector or panel itself
POWER	220 VAC Operate
ON	Operation LED for each detector (8 green LEDs)
FAULT	Fault LED for each detector (8 yellow LEDs)
ALARM	ALARM LED for each detector (8 red LEDs)

Table 2: Front panel signs and meanings

There are four buttons nearby LCD screen to perform configuration and display the detector details. Their functions are given in table (The key assignments may vary depending on the menu page):

Key	Function For Configuration	Function For Display Operation
MENU	Enter to panel configuration	OK - Select key
UP	Go to upper menu option during configuration	Go to the single channel details in normal operation
DOWN	Go to lower menu option during configuration	Page change on main screen
EXIT	Undo or exit from menu option	Reset on main screen

Table 3: Panel buttons and functions



Diagram 8: Front panel signs LCD and LEDs

S-DP8 Panel has LEDs formed in 8 columns and three rows. LEDs are grouped per channels and each channel has ON, FAULT and ALARM LEDs to show actual status of the detector. C1, C2, C3,...C8 numbers used to identify channels and each column indicate the detector information as follows:

- ON** : Indicates detector on related channel is working and communicating to system
- FAULT** : Indicates detector on related channel is in fault condition or not communicating
- ALARM**: Indicate detector on related channel has reached specified threshold level

LCD Screen:

LCD screen shows time details and status of each detector connected to channels as shown in Diagram 8. As The LCD screen can show 6 lines at same time there are two pages that you can move via UP and DOWN buttons:

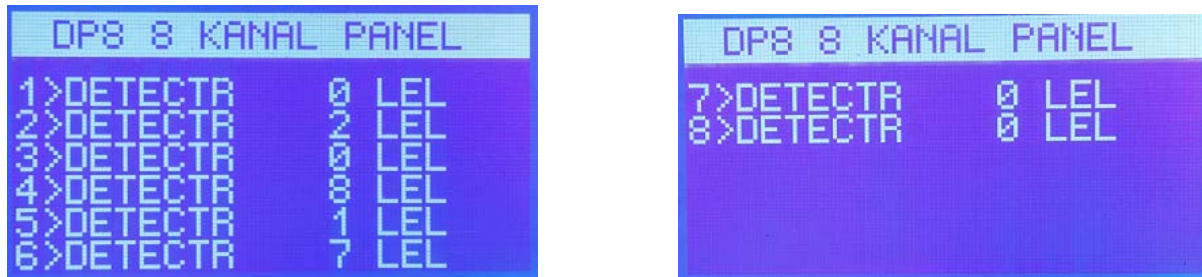

Diagram 9: LCD screen first and second page

Note: Date and time information will be unavailable when RS485 module installed.

The meaning of the signs used in LCD screen is given in table 4:

Column	Sign sample	Meaning
1	1>	Channel number
2	DETECTR	Detector name (user can give any name)
3	17	Gas level measured by detector
4	LEL	(LEL, VOL, PPM) measurement unit of detector
5	A1	ALARM1 is active
5	A2	ALARM2 is active
5	FLT	FAULT status

Table 4: LCD screen details

If there is no detector connected to channel, LCD screen will show it as FLT and fault LED will be activated. That channel should be closed (deactivated) via using menu steps.

The LCD screen brilliance is adjustable by blue potentiometer shown in Diagram 9.

Special States

Panel can recognize any special state in 2 minutes. Special States are:

- Fault
- Overrange

Below messages will be shown on LCD and related visible alerts will be activated:

Status	Screen Output	LED Output	Relay Output
Fault	Fault status on related channel	Fault LED	Fault Relay de-energised
Overrange	"Range<" message shown on related channel	ALARM LEDs	Alarm Relay(s) energised

Table 5: Special state and indicators

Fault Status:

The panel reports FAULT status in below cases:

- In case any of the detector connections lost
- In case any of the detector measurement level goes below minimum level
- In case any of the detector goes in to fault state

- In case any panel self-test result reports a fault
- In case panel main power lost and while panel is working with battery power
- In case panel main power supply fails

This status has been detected by panel when an input signal is below 3mA and reported on LCD screen on related channel with "FLT" symbol. Panel will activate FAULT relay and LED in case of any fault. Panel also activate fault LED for related channel if the fault status detected on a detector channel.

Fault relay is normally energised, and it will be de-energised when any of the internal fault detection measures detects a fault. The Fault LED will be activated also when line power is lost and system runs with battery power. It is also possible to get an alarm when control panel totally loses the power.

Overrange Status:

The panel reports overrange status in case any of the channels reported measurement higher than measurement range. This status has been detected by panel when an input signal is over range (> 20mA) and reported on LCD screen on related channel with "Range<" symbol and measurement level fixed to 99LEL. The overrange condition is highest measurement level that panel can understand and overrange level is higher than alarm levels. The alarm LEDs and relays will be activated before panel reports overrange condition.

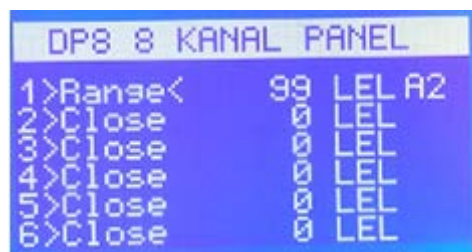

Diagram 10: Overrange status display

Alarm Status:

The Panel will report Alarm status when gas level exceeds defined alarm levels on any of the detector channel. Panel has two adjustable measurement alarm levels. If any connected detector measurement reaches the given alarm threshold level, panel will activate related alarm relay and LED. Alarm-1 relay and LED will be activated in case any of the connected detector measurement reaches defined Alarm-1 threshold level. Panel will show "AL1" symbols for the related channel on LCD screen and also activate alarm LED on related channel. Alarm-2 relay and LED will be activated in case any of the connected detector measurement reaches defined Alarm-2 threshold level. Panel will show "AL2" symbol for the related channel on LCD screen and also activate alarm LED on related channel. Alarm-1 and Alarm-2 relays and LEDs will be both active in case any of the connected detector reports Alarm-2 status.

Main Board and Connections

S-DP8 Control panel has one integrated main board. All components and connections are located on main board.

Main Board Details:

S-DP8 Control panel has all connections on main board.

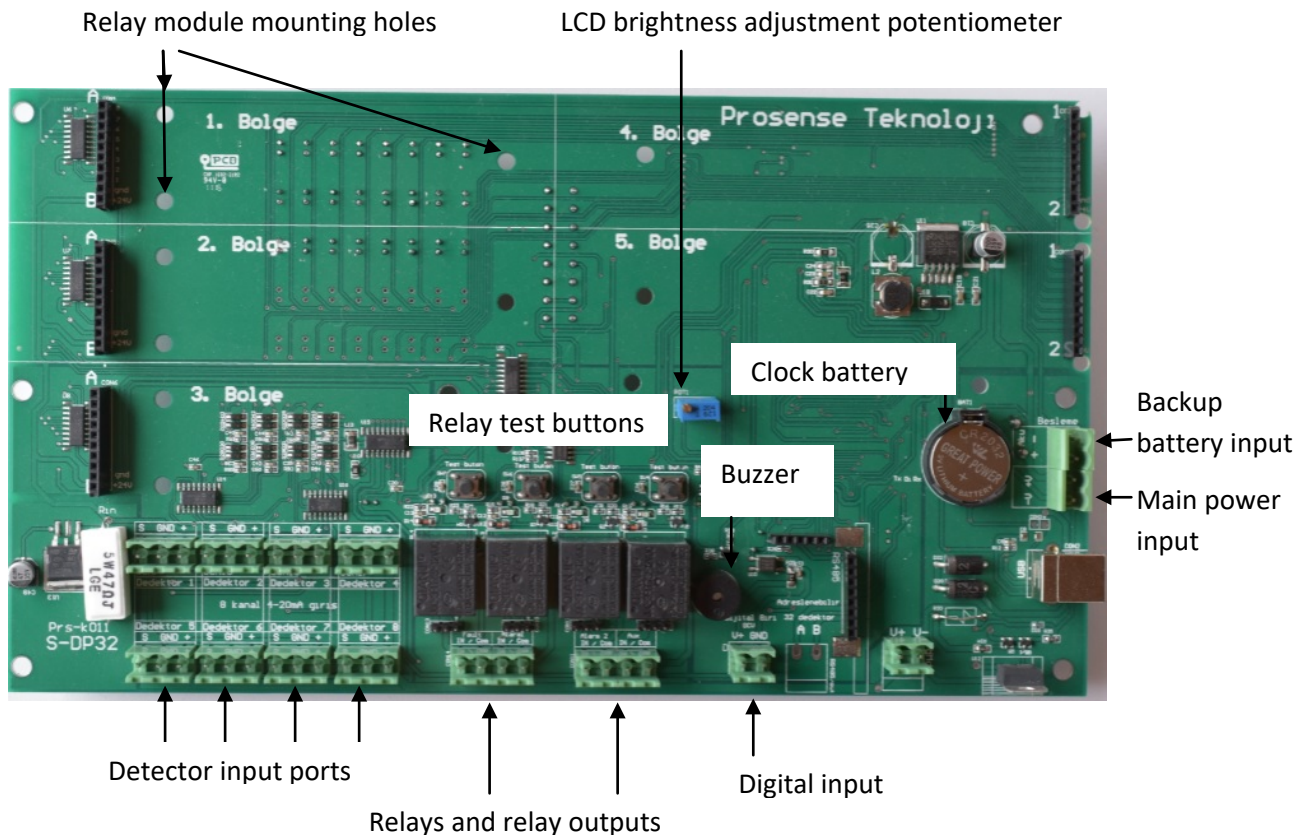

Diagram 11: Control panel main board

As shown in the picture, there is a 3V battery on the panel electronic board to keep data and time information. It may operate during the normal lifetime of the control panel. It should be replaced when it is run off.

There are five sockets on the main board to install optional relay modules. Each relay module has 8 relay on it and each relay controlled by one detector. It is also possible to take an independent output from each relay (each detector). The relay module install location should be used as follows:

1. Zone (1. Bölge): Not in use
2. Zone (2. Bölge): Fault
3. Zone (3. Bölge): Alarm 1
4. Zone (1. Bölge): Alarm 2
5. Zone (1. Bölge): Not in use

There are 4 cube relays on main board and relay outputs can be taken from the terminals on the bottom of relays. The relays are used for Fault, Alarm 1, Alarm 2 and Aux outputs. There are test buttons at the top of each relay that can help to generate artificial alarms for testing purposes.

S-DP8 Panel has a buzzer on the main board to generate sound alarms. A digital input port provided on main board that should be 24VDC. To activate this input the AUX relay must be defined as Alarm-3 to work with digital input. Otherwise it does not provide any output.

The detector connections are located on left bottom side of the controller panel board.

Not: The electronic board may become hot when the panel is in alarm status for a long time.

Backup Battery Connection

To continue operation in case of main power failure two backup batteries (12V 7Ah) must be serially connected to the system. Take extra care to connect the batteries with correct poles. The cables or main board can be damaged in case of mixing pins or making short circuits. Backup batteries must be connected as shown below.

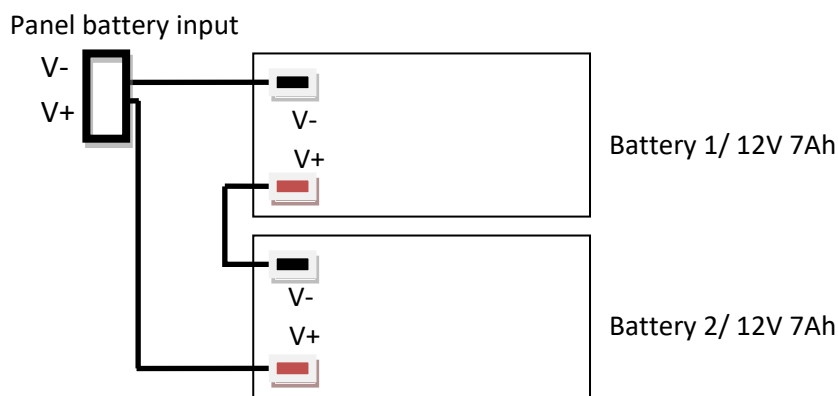

Diagram 12: Backup battery connection

Main Power Connection

Connection must be made three-wire 1.5mm² cross section cable to the main supply terminal entries and fixed by using cable fastener on the terminal. Make sure all the detectors connected properly before applying the power.

Name	Type	Usage
L	input	Phase
Gnd	input	Ground
N	input	Neutral
V+	output	+24VDC (Only for panel and detectors, do not use for any other device)
V-	output	-VDC

Table 6: Main power connection details

Detectors Connections

Panel can be connected and monitor 8 detectors with standard 4-20mA inputs signal. V+, V- (GND) and S ports must be connected via using three-wire cable. Detector connections supply 24VDC power to detector and read the output signal of detector from S port. Thus connections should be made correctly to do not cause any damage on the detectors. Detectors should be connected with three-wire 0.5mm² cross section cable. Cable diameter will be increased while distance increase between the panel and detectors. Recommended cable types per distance are given in table 6:

Cable size (cross sectional area)	Cable type nearest equivalent	Cable resistance Ω/km	Maximum Cable length (L) Meters
0.5mm ²	20AWG	36.8 Ω/km	400
1.0mm ²	17AWG	19.5 Ω/km	750
1.5mm ²	16AWG	12.7 Ω/km	1000
2.0mm ²	14AWG	10.1 Ω/km	1250
2.5mm ²	13AWG	8.0 Ω/km	1500

Table 7: Typical cable details and maximum distance for cabling

Detector connections should be made with 3 core cable and pin definitions are as follows:

S	4-20mA signal
-	GND (V-)
+	Supply (V+)

Table 8: Connection pin definitions

The panel is programmed as all channels in operation and connected to detectors. In case less than 8 detectors used the system will raise fault status for unused channels and overall panel status remain in fault status. In this case user should close (deactivate) unused channels via using configuration menu steps.

Relay Outputs

S-DP8 panel has four relay outputs which are ALARM1, ALARM2, FAULT and AUX. Relay connection ports are located right under the relays. Alarm relays are operating in latched mode. Hence the panel will wait user intervention to clear alarm status even conditions returned to normal. User should reset status via pressing Exit button to acknowledge any alarm. The active relays can also be monitored via related LEDs on the panel. Relay details and activation rules are given below:

ALARM1: This relay will be activated when any of the detectors in the system will exceed the programmed Alarm-1 level threshold. If there is oxygen detector used in the system, ALARM1 is also used as the low oxygen level alarm.

ALARM2: This relay will be activated when any of the detectors in the system will exceed the programmed Alarm-2 threshold level. If there is oxygen detector used in the system, ALARM2 is also used as the high oxygen level alarm.

FAULT: This relay is normally energised, and it will be de-energised when any of the internal fault detection measures detects a fault. The Fault LED will be activated also when line

power is lost and system runs with battery power. It is also possible to get an alarm when control panel totally loses the power.

If needed user can obtain independent alarm and fault outputs from each detector via using optional relay module. Relay modules should be installed reserved zone sockets explained earlier. The relays are configured as NO (normally open) by default at factory. The relay configurations can be adjusted via putting jumpers under each relay. Relay will not provide output while jumpers are omitted or not installed. Relay connections pins are:

NC : Normally closed contact pin (Select by jumper under relay)

NO : Normally open pin (Select by jumper under relay)

COM : Common pin

Note: Relays should not be connected to high current or 220V AC loads. The relay outputs should be used as control signal and external relays should be used to drive such devices as relay on main board cannot handle high load.

AUX Relay Output

Aux relay can be programmed from the main menu on the panel to match to ALARM1, ALARM2 or ALARM3. When ALARM1 is selected, AUX relay will operate simultaneously with ALARM1 relay of the system. When ALARM2 is selected, AUX relay will be active when ALARM2 relay activated. When ALARM3 is selected, AUX relay will be active by the digital input on the panel. In case of any alarm signal received from external device it will be shown in 9th line on LCD as digital alarm.

First Run

Panel manufacturer (Prosense) and model (S-DP8) will be seen on LCD screen following the power-up. All LEDs on the panel and sounder device will be activated for 3 seconds. The user can recognize any malfunctioning LED on panel at this period. The Fault relay and LED will be activated during the warm-up period. The panel will start searching channels one by one and activate the channel power and fault LEDs. This operation may take two minutes. During this period, system will operate in standby mode until the detectors are warmed up. Instantaneous alarms will be turned off during the warm-up period.

Panel will activate status LEDs per channel depending of the detectors connected to each channel following search and warm-up time. Also status will be shown on LCD screen. If all of the detectors run smoothly, the Fault LED will turn off.

Automatic Test

DP-8 gas control panel simultaneously monitor all detectors connected to it. Panel should have power LED and connected detector Channel ON LEDs during normal operation. S-DP8 panel also runs internal component tests at the warm-up time and every 8 hours. The FAULT relay and LED will be activated in case any problem. Alarm and fault status can be monitored on the screen and related detector LEDs.

Programming

The panel is already programmed and ready for using when shipped. User should adjust the alarm settings via changing alarm levels for each channel depending on the detectors installed. Each channel parameters should be adjusted regarding related detector measurement unit and range. These adjustments can be done via using the keys nearby LCD. Each detector can also be named in the menu. The menu steps are given in Diagram 11.

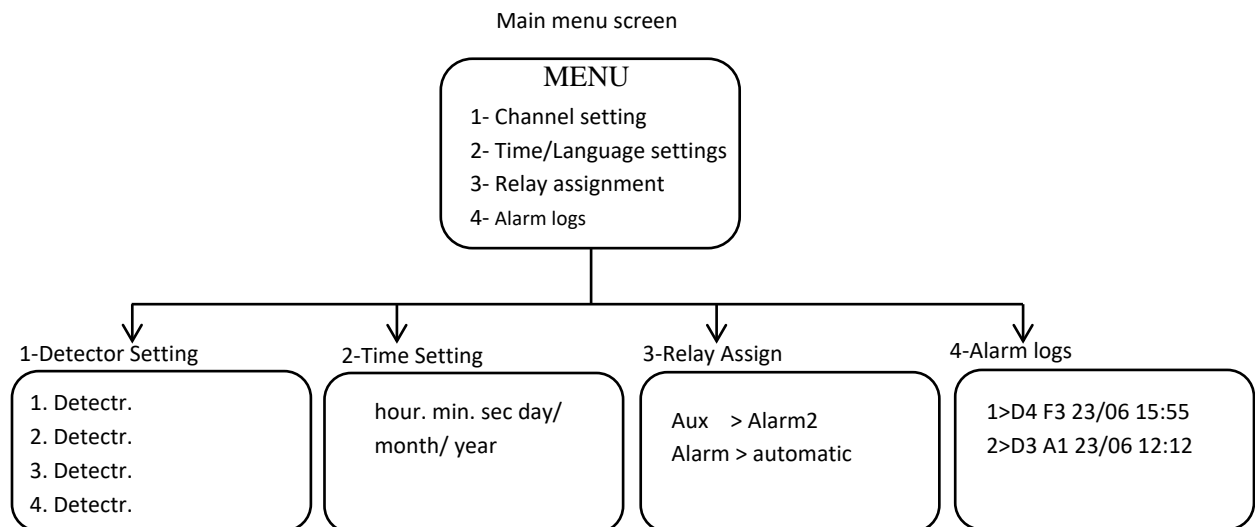

Diagram 13: Menu structure

S-DP8 control panel keeps data and time information to record alarm events in the internal log space. The alarm logs menu is not available when panel uses RS485 module to communicate to Prosense Panel Monitor software.

To activate configuration menu, press and hold the MENU button for a second. You can navigate between the menu items via using the UP and DOWN keys. Press MENU key again to enter submenu. You can EXIT from submenu or menu by pressing the EXIT button.

1. Channel setting
2. Time / Language settings
3. Relay assignment
4. Alarm logs

Setup Channel Parameters:

To adjust channel parameter follow below steps.

1- Press Menu button for 2 seconds. The screen will display menu options:



2- Select Channel setting via pressing the MENU button. Screen will list channels:



3- Move desired Channel from the list via using UP and DOWN buttons and press MENU button to select channel. A new menu will display with below options:

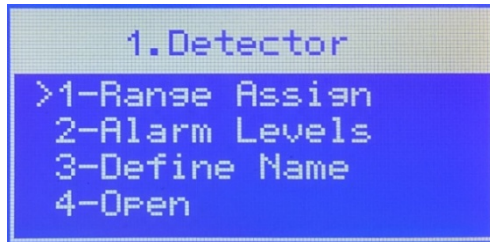

4- To adjust measurement range select "Range Assign" option. Screen will display default measurement settings:

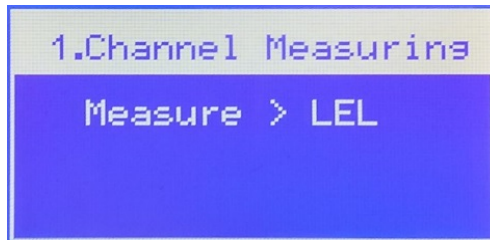

You can change measurement type via pressing up and down buttons to select LEL, VOL, and PPM. Once selected press MENU button. Then screen will display Range options:

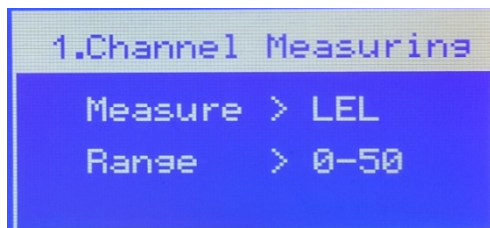

You can select below values for range

for **LEL**: 0-50 or 0-100

for **VOL**: 0-5 or 0-25 or 0-30

for **PPM**: 0-10 or 0-20 or 0-30 or 0-100 or 0-200 or 0-250 or 0-300 or 0-400 or 0-500 or 0-1000 or 0-5000

Once selected press EXIT button to return Channel Settings menu.

5- To adjust alarm levels first you have to complete measurement range settings. Then move "Alarm levels" option on channel setting screen and select via pressing MENU button. Screen will display default alarm level settings:

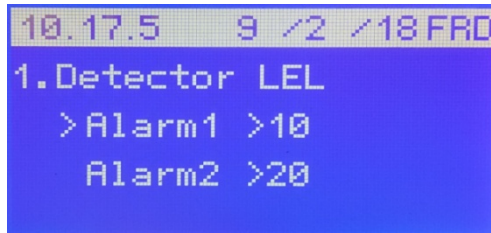

6- When press MENU button a cursor will be located under Alarm1 level. You can adjust alarm level via using UP and DOWN buttons.

7- Then press EXIT button to release the cursor.

8- Then you can move Alarm2 via using UP or DOWN buttons.

9- Press MENU button again to activate cursor and adjust level using UP and DOWN buttons.

10- Once all completed press exit button to return the previous screen.

Alarm1 level cannot be higher than Alarm2 level. Hence it would be easier to adjust Alarm2 level first before adjusting Alarm1 level.

11- You can give a name to channel instead of default "Detectr". Move "Define Name" option on Channel Settings screen via UP and DOWN buttons and select via pressing MENU button. The screen will show default name and cursor:

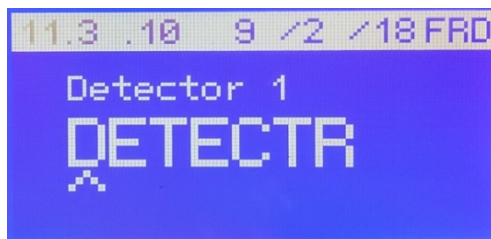

You can change each letter via using UP and DOWN buttons. Press MENU button to record and move to the next letter.

12- Once all completed press EXIT button to return main menu.

Closing Unused Channels:

Unused channels should be deactivated if not all channels used on control panel. Otherwise unused channels and control panel will stay in fault status. To deactivate unused channel go to the Channel Settings menu via pressing the MENU button. Then move related channel via using UP and DOWN buttons and select channel with MENU button. You will see the below detailed settings menu:



The fourth step on this menu pointing the actual status of the channel. "Open" means channel is active. To close this channel move to the option 4 on screen via UP and DOWN buttons then press MENU button to change status. It will be deactivated and shown like below:

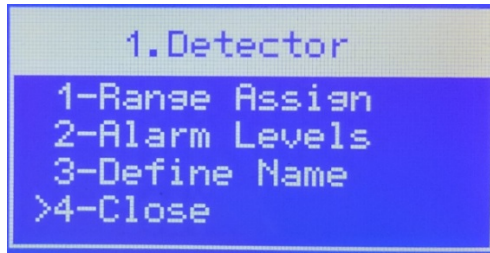

Relay Assignment:

The alarm relays work only in latched mode. Therefore, the relay will not be released and stay in active mode till manual intervention. Even after environment is cleaned following an alarm condition, the relay will stay active in latching mode. User should release them via pressing the EXIT button for 2 seconds. Pressing the EXIT button will reset and stop alarms temporarily. The control panel will perform measurement again when user released the EXIT button. If gas measurement is still higher than given threshold levels alarms will be activated again.

To change relay assignment press MENU button on main screen and select “Relay Assign” option. The screen will display default working mode for all relays and assignment for AUX relay:



Press MENU button to change AUX relay assignment. A cursor will be activated on the screen and you can change assignment via using UP and DOWN buttons. Press EXIT button to save assignment and return the screen. When AUX relay assigned to ALARM3, Digital Input port will be activated on the panel. In this case it will be shown as 9th line on LCD as “Digital Alarm” in case an alarm status received from external device:



Time and Language Settings:

Press MENU button and select “Time/Lang. Set” step to change time and date. If communication module installed on the menu will show only Language options. A new menu will be displayed including time and language options:

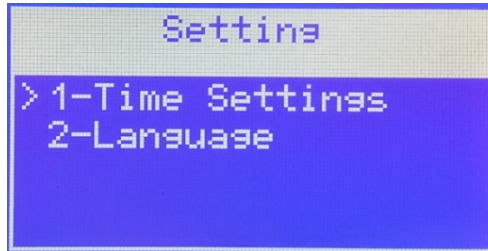

Press MENU button to adjust time. Screen will show current time and date information on the control panel.

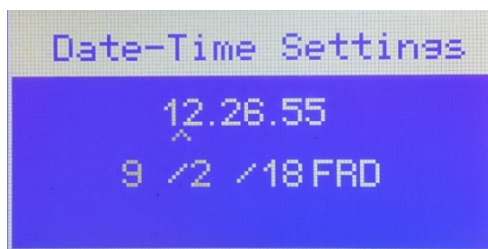

Use UP, DOWN and MENU buttons to change value and move to the next item on the screen. Once completed press EXIT button to return to settings screen.

You can change the screen language on Language menu. Only Turkish and English languages available at the time of writing this manual:

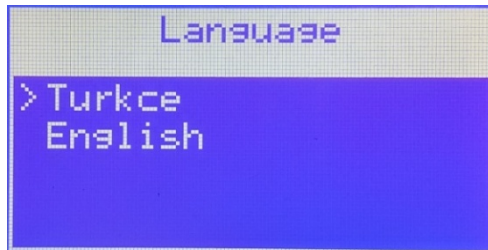

What to Do In Case of Alarm

There are 3 independent LEDs for each detector as fault, alarm and power LEDs. In addition to them there are two alarms, one fault, one power and one battery LED used to monitor overall panel status. ALARM1 and ALARM2 LEDs will be activated and kept active when any of the detectors raised an alarm. The LEDs and related relay outputs will be active until detector changes the alarm status and alarms acknowledged by user.

Checking Alarm and Fault Functions

The main board has 4 test buttons on top of each relay to generate false alarm and test relay function. Relay functions can be tested by pressing to test buttons after completing cabling. The relay will be activated while pressed the test button and deactivated when button released.

Important: Test buttons do not provide functionality to check that the control unit will actually react at a specific gas concentration. This can only be achieved by applying a calibration gas on the detector.

Please refer to the mandatory safety procedures (gas alarm) set forth by your safety manager in case of any alarm. Here are few recommendations:

Keep calm and follow these instructions:

1. Put out all naked flames (including cigarettes, pipes, etc.)
2. Turn off all gas appliances.
3. Turn off the gas supply at the tap and/or on the gas bottle (in the case of LPG).
4. Do not switch electrical appliances, lamps or the gas detection control unit on or off.
5. Open all windows and doors to air the room.
6. Do not “reset” the control unit if it is in the same room.

If the gas concentration reading on the control unit does not fall below the level of alarm, and the reason for the gas leak is not immediately apparent and/or cannot be repaired, quit the premises and call the gas supplier and/or emergency services immediately to check the installations and to make the premises safe and to possibly carry out the necessary repairs. If the alarm stops and the reason for the alarm is identified and resolved (e.g. a kitchen burner lit off but in the open position) the gas supply may be re-opened after checking that all the gas appliances are off.

Controlling The Alarm Fault Functions

	PROBLEMS	POSSIBLE CAUSES	WHAT TO CHECK
1	The display is not on	Main power source is OFF	Check the Main power connection
		Bad power supply.	Check the power supply. The green LED should be on
		Blown fuse(s).	Check fuses on main power connection and replace if necessary.
2	BATTERY LED is ON	No line power, System is using Backup battery	Check line power and related fuses
		Power supply range is below 27 V	Adjust power supply output level via Phillips screwdriver
3	FAULT LED is ON and FLT sign shown on LCD screen	The Detector connection is broken	Check the detector cables
		The detector output signal is too low	If detector is working fine the output current might be getting low at control panel input. Adjust the zero level of the detector.
		There is no detector connected to channel	Close (deactivate) related channel via using menu steps
		Detector is faulty	Check detector connected to channel
4	ALARM1 and/or ALARM2 and/or AUX LED is ON	There is a gas leak.	Close the manual valve on the gas input pipe. Locate and repair the leak.
5	ALARM1 and/or ALARM2 and/or AUX LED is ON and there is no gas leak	The control panel has false alarms	Reset control panel
		Alarms might stuck due to previous gas leak	Press EXIT button for 5 seconds to reset the panel

Table 9: Problems and possible causes

Prosense Panel Monitor Software Option

Prosense S-DP8 Control Panel has an optional RS485 module and connections on main board. Prosense S-DP8 Control panel with firmware version V3.02 can communicate to Prosense Panel Monitor Software control program via RS485 module. S-DP8 panel with earlier than V3.01 firmware version needs hardware upgrade to enable RS485 module.

Important: The date and time information will be unavailable once RS485 module installed.

Declaration



Manufacturer Declaration of Conformity



Prosense Teknoloji San Ltd. Şti declares the DP Series products to be in accordance with the following standards and directives.

Name and address of Manufacturer: Prosense Teknoloji San Ltd Şti
Cumhuriyet Mah. Mermer Sok No:16
34876 - Kartal - İstanbul - Türkiye

Description of Devices: DP Series Fixed Type Gas Control Panel

Designation: [Ex Gb] IIC

Applied Harmonized international standards:

- IEC EN 60079-0:2017 (Ed. 7.0) Equipment – General requirements
- IEC EN 60079-29-1: 2016 (Ed. 2.0) Gas detectors – Performance requirements of detectors for flammable gases
- IEC EN 50271:2018: Electrical apparatus for the detection and measurement of combustible gases, toxic gases or oxygen - Requirements and tests for apparatus using software and/or digital technologies

Applied European Directives:

- 2014/30/EU Electromagnetic Compatibility (EMC)
- 2014/35/EU Low Voltage (LVD)

DP Series Fixed Type Gas Control Panel complies to below rules given in IEC EN 60079-29-1:

- Unpowered storage (§5.4.2 IEC 60079-29-1)
- Calibration and adjustment (§5.4.3 IEC 60079-29-1)
- Alarm set point(s) (§5.4.5 IEC 60079-29-1)
- Temperature test (§5.4.6 IEC 60079-29-1)
- Vibration test (§5.4.12 IEC 60079-29-1)
- Warm-up time (§5.4.14 IEC 60079-29-1)
- Time of response (§5.4.15 IEC 60079-29-1)
- High gas concentration operation above the measuring range (§5.4.16 IEC 60079-29-1)
- Power supply variations (§5.4.18 IEC 60079-29-1)
- Verification of software and digital components (§5.4.23 IEC 60079-29-1)
- EMC Test performed according to Tab.2 of IEC 61326-1:2012

Each DP Series gas control panel device which Production Quality Assurance procedures and Type Examination procedures have been applied has been shown to conform to an approved Type and to the applicable classification rules and essential principles before being supplied. This declaration is being made on the basis of the following certificates:

Production Quality Assurance Certificate: ExVeritas 18PQAN0072

Authorized Signatory: **Firat Celep**
Production Manager

Date: 05.03.2020

Warranty Statement

All products are designed and manufactured to the latest internationally recognized standards by Prosense Technology under a Quality Management system that is certified to ISO 9001. As such Prosense Technology warrants its products against defective parts and workmanship and will repair or (at its option) replace any instruments which are or may become defective under proper use within 12 months from date of commissioning by an approved Prosense Technology representative or 18 months from date of shipment from Prosense Technology, whichever is the sooner. This warranty does not cover disposable batteries or damage caused by accident, abuse, abnormal operating conditions or poisoning of sensor.

Defective goods must be returned to Prosense Technology premises accompanied by a detailed description of any issue. Where return of goods is not practicable Prosense Technology reserves the right to charge for any site attendance where any fault is not found with the equipment. Prosense Technology shall not be liable for any loss or damage whatsoever or howsoever occasioned which may be a direct or indirect result of the use or operation of the Contract Goods by the Buyer or any Party.

This warranty covers instrument and parts sold to the Buyer only by authorized distributors, dealers and representatives as appointed by Prosense Technology. The warranties set out in this clause are not pro rata, i.e. the initial warranty period is not extended by virtue of any works carried out there under.

In no event will Prosense Technology be liable for any incidental damages, consequential damages, special damages, punitive damages, statutory damages, indirect damages, loss of profits, loss of revenues, or loss of use, even if informed of the possibility of such damages. Prosense Technology's liability for any claims arising out of or related to this product will in no case exceed the order value. To the extent permitted by applicable law, these limitations and exclusions will apply regardless of whether liability arises from breach of contract, warranty, tort (including but not limited to negligence), by operation of law, or otherwise.